

SUBMITTAL



Heavy Duty Round Modulating Supply Damper

***Controlled by Wireless Programmable Thermostat
Part #WRD**

DESCRIPTION

The **WRD** is a fully modulating pressure dependent supply air damper. The damper is equipped with a damper board designed to support and communicate with a Zonex wireless programmable thermostat. The dampers are available from 20", 22" and 24" round, with a maximum pressure differential of 1.75" W.C.

WRD dampers feature a round frame and triple V blades for automatic air control.

Damper cylinders and blades are fabricated from 16 gauge steel. Each damper is built with low leakage seals and stainless steel bearing.

WRD dampers feature 24V ac, full stall motors which do not require end switches. Each damper is controlled by its respective zone thermostat.

WRD dampers can be paralleled to provide additional CFM capacity when required.

Damper actuators can be easily removed from damper for servicing and motor inspection. Each actuator hat section is insulated to prevent condensation. The actuator allows for minimum and maximum stops for air balance.

TECHNICAL DATA

Electrical:

Supply Voltage: 24vac

Power consumption: 2 VA maximum (1.5W)

Environmental:

Operating temperature: 25 to 180° F (-32 to -83°)

Operating humidity: 10-95% non-condensing

Storage temperature: -25 to 180° F (-32 to -83°)

General:

Shell: 16 gauge cold rolled galvanized steel

Shaft: 1/2" dia. aluminum, hexagonal

Bushings: Synthetic

Actuator: Power Open / Power Close

Stroke: 90°

Pressure drop: < .04" W.C. @ rated CFM

Communication:

Proprietary wireless network protocol, with up to 100' transmission range.

Notes:

*Compatible only with GEN III VVT and SubZone wireless systems.

Typical Capacities

	Diameter	Nominal CFM	Velocity FPM	ΔP "WC
WRD20	20"	2600	1200	.10
WRD22	22"	3250	1250	.10
WRD24	24"	4100	1350	.10

* Capacities are for reference only. Duct friction rate should be established by use of ACCA Manual D, Manual Q or equivalent.

ORDERING INFORMATION

Part No.	Description
WRD20	Medium pressure zone damper, round, 20" diameter.
WRD22	Medium pressure zone damper, round, 22" diameter.
WRD24	Medium pressure zone damper, round, 24" diameter.

TERMINAL FUNCTIONS

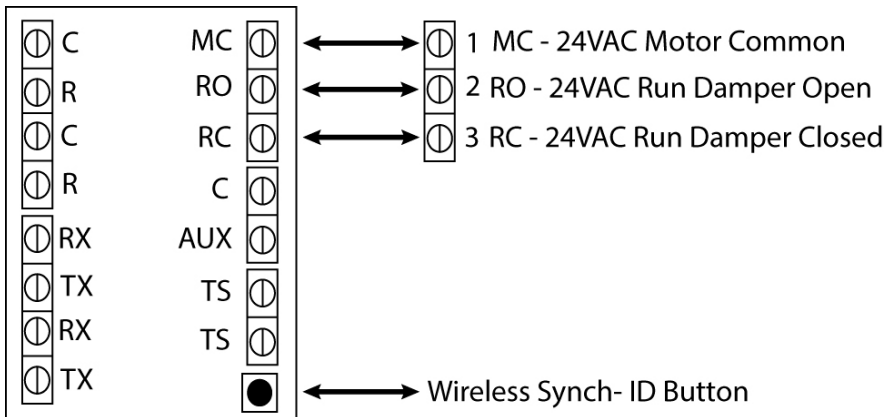

TERMINAL CONNECTIONS

R - 24VAC power input In / Out
 C - 24VAC power common In / Out
 RO - Damper run open signal
 RC - Damper run closed signal
 MC - 24VAC motor common
 TS - Duct temperature sensor
 TS - Duct temperature sensor
 AUX - Auxiliary Heat
 RX - Data Receive In / Out
 TX - Data Transmit In / Out