

SUBMITTAL



Fresh Air Ventilation Humidity Mitigation System (FAV-H)

DESCRIPTION

Zonex Systems Fresh Air Ventilation - Humidity Mitigation System, **Part # FAV-H** is a microprocessor based controller and fresh air damper designed to provide required ventilation air based on time, outside air temperature/humidity and air requirements for 12-hour operations..

Using sophisticated software, the controller will monitor HVAC operations to align fresh air intake with compressor operation using existing mechanical equipment to remove moisture from air prior to entering the home or dwelling. If desired an FAS, fresh air sensor may be used to measure total outside air enthalpy and enable DEHUM functions on Air Handler or Furnace for greater moisture removal. FAV-H controller will track HVAC system operation and provide fresh air when the system can remove humidity during its run time. FAV-H controller will track minutes of operation each 12 hours of operation, if HVAC system operations do not permit required fresh air intake software logic will determine when to energize system, open fresh air damper and energize fan to provide required fresh air to meet ASHRAE 62.1 or IMC 403.3.2.1 Code requirement.

Additionally, the FAV-H controller may be paired with a FAS enthalpy sensor to monitor outdoor air temperature and humidity to determine shoulder periods, events when outdoor air temperature is moderate and humidity is high, and activate dehumidification function from FAV-H controller to HVAC air handler / furnace. If air handler / furnace is equipped with DEHUM feature, fan speed will be reduced allowing for greater dehumidification of fresh air entering the home.

A 50% run strategy may be configured using this controller when design requires fresh air 50% or 30 minutes of each hour.

TECHNICAL DATA

Electrical:

Supply Voltage: 24vac – Controller and Damper
Power consumption: 12va

Inputs:

R and C - 24vac power from HVAC unit transformer
Y- from Furnace/Air Handler
J Plug – Outdoor Air Temperature and Humidity Sensor

Outputs:

G – Energize Blower Fan Furnace/Air Handler
DPR 1 and 2 – Energize fresh air damper open
EXH – Optional booster fan output
DH- Activate DEHUM operation on Furnace/Air Handler if equipped.

Environmental:

Operating temperature: 10 to 150° F

General:

Frame: 20 gauge galvanized steel
Actuator: Power Open, Spring Closed

JP1 jumper: Allows for 50% run per hour

REV 4/22/17

FAV-H

Wiring Diagram using Furnace / Air Handler Blower Motor

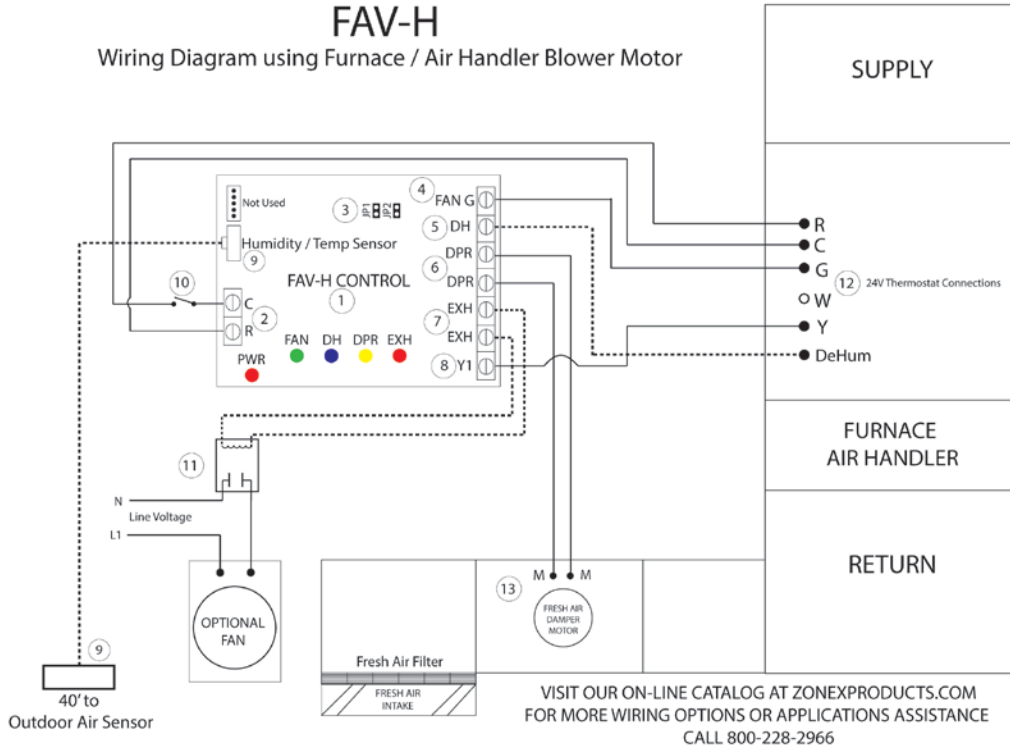

- | | | |
|---|---|--|
| 1. FAV-H Controller | 5. Dehumidifier output (For use with Furnace / Air handler equipped with Dehum function) | 9. FAS - Temperature Humidity Sensor |
| 2. FAV-H 24v Power provided from Furnace / Air handler | 6. Damper control output | 10. Optional " On - Off" Switch (Field Supplied) |
| 3. JP1- Used for 50% operation
JP2 - Exhaust Fan Jumper | 7. EXH outputs to operate AUX Booster Fan or Exhaust Fan | 11. Field Supplied SPST Relay to be used with Optional Booster / Exhaust Fan |
| 4. G output, connect to G on Furnace / Air handler control terminal | 8. Y1 input, connect to Y1 on Furnace / Air handler control terminal | 12. Furnace / Air handler 24V Thermostat Connections |
| | | 13. Fresh Air Damper |

Fresh Air Duct Sizing Chart

Required CFM	Duct Size
40	5"
50	6"
60	6"
75	6"
90	7"
100	7"
105	8"
110	8"
125	8"

Fresh Air Duct Sizing is based on .3 inch of static for a 100 ft. run of duct. An air balancing damper may be used to tune airflow to specific CFM requirement.