



*comfort you control*

**Design & Installation for**

# Zonex Systems System 2000

2-20 Zone Auto Changeover

# System 1000

2-7 Zone Manual Changeover

# TABLE OF CONTENTS

## System 2000

System Operation .....	1
Components .....	1
Component Selection Guide .....	2
System 2000 System Controllers.....	3
Gas/Electric (101ASSB) .....	3-5
Heat Pump (101AACBHP) .....	5-7
Startup .....	8

## System 1000

System Operation .....	9
Components .....	9
Component Selection Guide .....	10
System 1000 Switching Centers	
Gas/Electric (SYGE) .....	11, 12
Heat Pump (SYHPA) .....	12-14
Startup .....	15

## Zone Thermostats .....

Remote Sensors .....	17
----------------------	----

## Zone Dampers .....

Round Zone Dampers .....	18, 19
Rectangular Zone Dampers.....	20, 21
Sizing Zone Dampers .....	22
Wiring Zone Dampers .....	22
Damper Installation Notes.....	22
Paralleling Zone Dampers.....	23

## Bypass Dampers .....

Barometric .....	23, 24
Electronic .....	25, 26
Bypass Position Indicators .....	26
Paralleling Bypass Dampers .....	26

## Bypass Damper Static Pressure Controller .....

## Capacity Controllers .....

101CAPGE.....	29, 30
TRLAT .....	31, 32
TRFPC.....	32
SYCAP .....	33, 34
101ALAS .....	35
CAPL-2 .....	36, 37
CAPL-4.....	38, 39
Capacity Controllers Installation.....	40
Capacity Controllers, Setpoints, Calibration .....	41

## Important Diagrams

Five Wire Link.....	41
Transformer/Fuse Sizing .....	42
Application Schematics .....	42, 43

# SYSTEM 2000

The System 2000 is a light commercial/residential zone control system. It enables a single HVAC unit to be controlled by up to twenty zone (room) thermostats. System 2000 is a vote based, auto changeover system. The system operates on a first call, first served majority wins on changeover strategy. To provide economical, effective and simplified remote control and monitoring capability of one or more System 2000 zone control systems,

the ZonexCommander may be used to manage up to 80 thermostat schedules. The ZonexCommander is a Window's based thermal management system, which can integrate gas/electric and heat pump zone systems to include stand alone HVAC systems. *For modulating communicating control, use the ZonexCommander (Plus).*

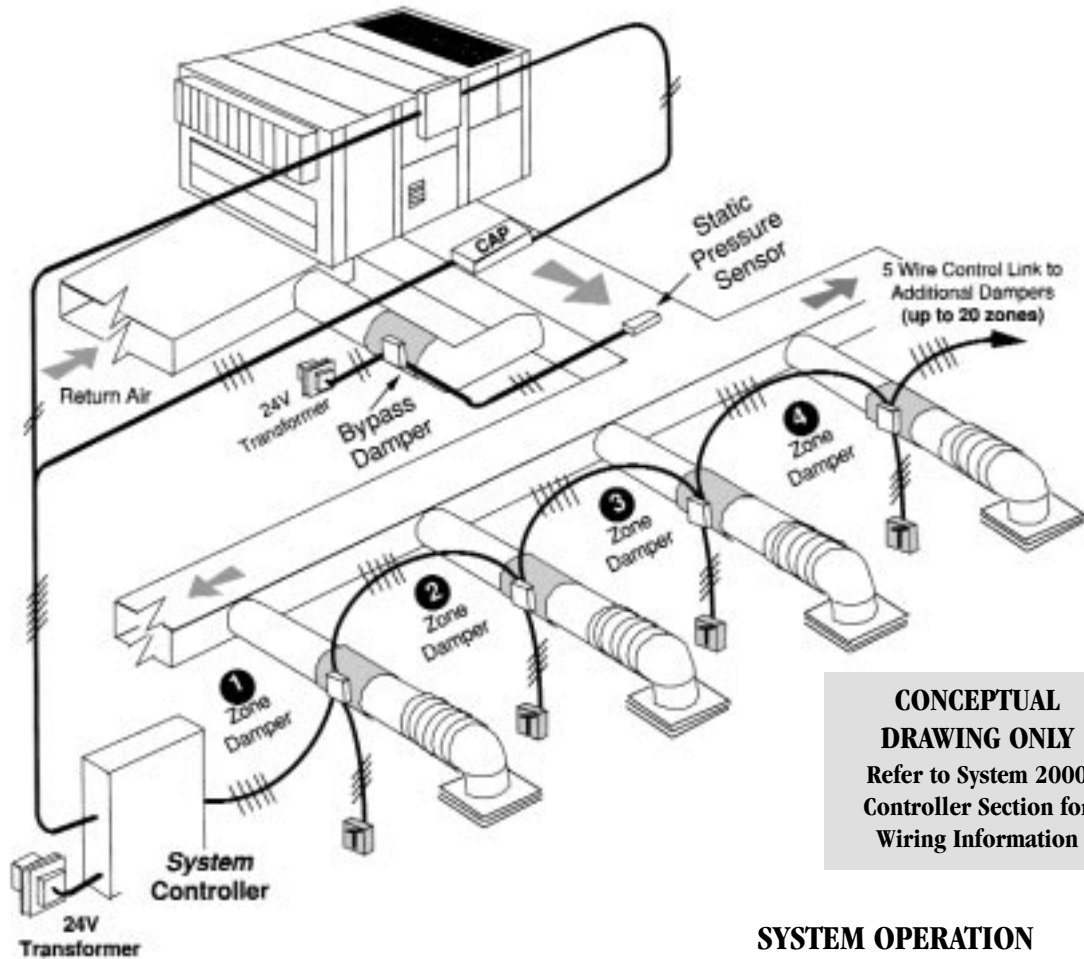

## System 2000

### Zonex Systems Supplied Components

System Controllers .....	Pages 3- 7
Zone Thermostats .....	Pages 16-17
Zone Dampers .....	Pages 18-23
Bypass Dampers .....	Pages 23-27
Capacity Controllers .....	Pages 28-41

## System 2000

### Field Supplied Components

Thermostat Wire .....	Page 41
24V Transformers and Fuse .....	Page 42

## SYSTEM OPERATION

The System Controller communicates with the Zone Dampers and Zone Thermostats via a patented Five-Wire Link. The Five-Wire Link is daisy chained from damper to damper using standard five-conductor thermostat wire. The System Controller polls every zone every 120 seconds and registers the number of thermostats calling for heating and cooling. The System Controller then runs the HVAC/Heat Pump unit in the mode with the most calls. If the majority changes, the System Controller will automatically change over to the new mode of operation.

The Zone Dampers are open for the zones calling and closed for the zones not calling for the operating mode. When the HVAC/Heat Pump unit is not running, all Zone Dampers are open to provide ventilation if the indoor blower fan is running continuously.

While the unit is running, the Capacity Controller monitors the leaving air temperature from the unit and will cycle the HVAC/Heat Pump unit off and on to maintain the air temperature within a preset range to eliminate coil freeze-up and premature heat exchanger failure.

# SYSTEM 2000 COMPONENT SELECTION GUIDE

*Auto Changeover for 2 to 20 Zones*

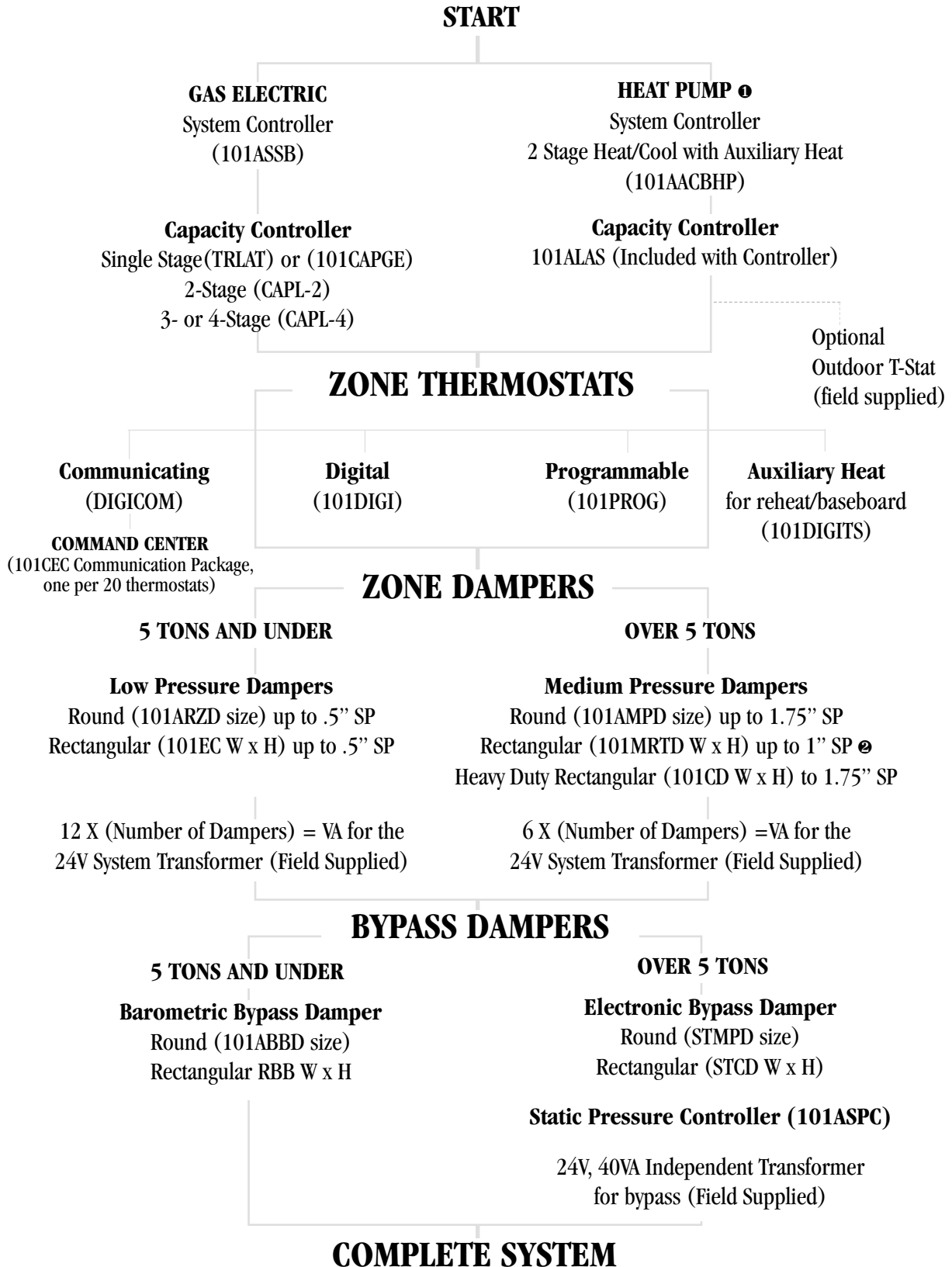

① Some Heat Pumps utilize Gas/Electric thermostats, typically units over 7.5 tons.  
For this application, use the Gas/Electric parts selection and field modify the capacity control heat cutoff setpoint to 118° F.

② Use heavy duty rectangular dampers on systems of 7.5 tons or larger

# SYSTEM 2000 CONTROLLERS



Dimensions 7" x 7" x 2.5"



Gas Electric System Controller  
(101ASSB)

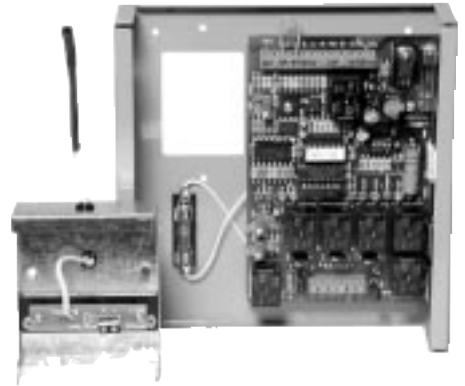

Heat Pump System Controller  
with LAS Sensor  
(101AACBHP)

## SYSTEM 2000 CONTROLLERS – GAS/ELECTRIC 101ASSB

### OVERVIEW

The 101ASSB is a Gas/Electric System Controller that will control up to 20 zones for the System 2000 zoning system. The System Controller selects the mode of operation based on a majority calls basis. It is used in conjunction with a Capacity Controller. The Capacity Controller controls the HVAC system staging. Capacity Controllers are available for one, two, three and four stage systems. Refer to Capacity Controller section (pg. 28) for further information.

The 101ASSB is a vote based, auto changeover System Controller. It polls each zone every 120 seconds, registering heat or cool calls. Majority wins, and the Controller operates the HVAC system in that mode until all calls are satisfied or it detects a majority of offsetting calls.

The System Controller should be located in an accessible, conditioned space. The Controller does not sense temperature; it simply receives data from the zone thermostats. The Controller communicates to the zone dampers and thermostats through a five-wire link. These five wires are daisy chained to each zone damper. This simple patented wiring process eliminates home run wiring.

### OPERATION

When heating or cooling calls are sent to the System Controller, the controller will treat these calls as votes.

**COOL CALLS** – If the majority of calls are for cooling, the System Controller will turn on the compressor and fan. The air conditioner will continue to operate until all cooling calls are satisfied or the majority changes to heating.

**HEAT CALLS** – If the majority of calls are for heat, the System Controller will turn on the heat. If the fan switch is set for auto, the bonnet control or a delay relay will start the fan. When all heating calls are satisfied or the majority changes to cooling, the gas valve will turn off.

**CHANGEOVER** – If the system is running in one mode and the majority of calls changes to the other mode, a timer will start. The System Controller will give the current operating mode another 4 minutes to try and satisfy the zone(s). It will then go into a 4-minute purge cycle before switching modes.

**PURGE MODE** – When a heat or cool call is satisfied or before changing modes, the System Controller will go into a 4-minute purge cycle. The compressor or gas valve will turn off and the indoor blower will continue to run. The dampers of any zone thermostat not satisfied in the previous mode will remain open. This allows the supply air to adjust to room temperature before changeover or ventilation while providing a time delay to prevent short cycling.

**VENTILATION** – When no zones are calling, all zone dampers open after the purge mode. This permits ventilation in all zones if the blower fan is on continuously.

# SYSTEM 2000 CONTROLLERS – GAS/ELECTRIC 101ASSB

## COMPONENTS

The 101ASSB System Controller consists of the following:

- A.** TB1 (Terminal Block 1): Wires to daisy chain, transformer and time clock.  
TC1, TC2 – Time clock switch terminals. Used for Select-Temp system only.  
S – Nite call. Used for Select-Temp system only.  
Y – Cool call.  
W – Heat Call.  
Rd – Damper close signal.  
B – 24V AC common. Same terminal as TR2.  
G – 24V AC hot. Same terminal as TR1 when PWR switch ON.  
TR2 – 24V AC common.  
TR1 – 24V AC hot.
- B.** Jumpers J1 and J2:  
J1 – Not used.  
J2 – Not used for System 2000. Used for Select-Temp system only.
- C.** Microcontroller: Responsible for zone communication, activation and control of outputs based upon zone demand and leaving air temperature. Occasionally software upgrades may become available. If so, the 101ASSB software can be field upgraded by changing this microcontroller.
- D.** Off board fuse: One amp. Protects Y and W terminals of TB1.
- E.** Status lights: Refer to status light section for details.
- F.** TB2 (Terminal Block 2): Wires to Capacity Controller and HVAC unit.  
R – HVAC unit 24V AC power  
W1 – Heat enable  
Y1 – Cool enable  
G – Indoor blower fan enable

- G.** FAN switch:  
AUTO – Turns on indoor blower fan when unit is running in cool mode.  
ON – Indoor blower fan runs continuously.
- H.** COOL and HEAT mode switches:  
AUTO – Accepts calls from thermostats.  
OFF – Ignores calls.
- I.** Power switch. When on, applies 24V AC power to G of TB1.
- J.** On board fuse. One amp. Protects 101ASSB board only.

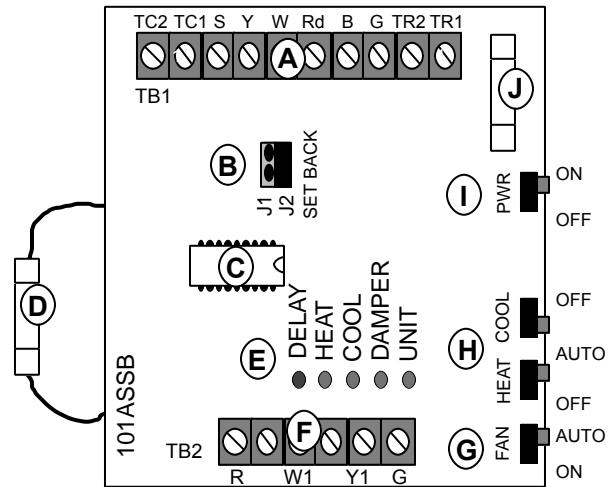

## STATUS LIGHTS

- DELAY** On when HVAC unit energized. Flashing when in purge/delay mode.
- HEAT\*** On in heat mode.
- COOL\*** On in cool mode.
- DAMPER** When on, dampers of zones not calling for present mode are closed.
- UNIT** On when HVAC unit energized.

Status Lights					Mode	Function
Delay	Heat*	Cool*	Damper	Unit		
0	1	0	0	0	Heat, no calls	HVAC unit off. All dampers open.
0	0	1	0	0	Cool, no calls	HVAC unit off. All dampers open.
1	1	0	1	1	Heat call	Heat energized. Heat calling zone dampers open.
1	0	1	1	1	Cool call	AC energized. Cool calling zone dampers open.
FLASH	1	0	1	0	Purge heat	Blower fan on, HVAC unit off. Heat calling zone dampers open.
FLASH	0	1	1	0	Purge cool	Blower fan on, HVAC unit off. Cool calling zone dampers open.

\*MODE LIGHTS TOGGLE BETWEEN HEAT AND COOL EVERY 120 SECONDS. THIS INDICATES THE SYSTEM CONTROLLER IS POLLING FOR HEAT OR COOL CALLS.

# SYSTEM 2000 CONTROLLERS - GAS/ELECTRIC 101ASSB

## WIRING

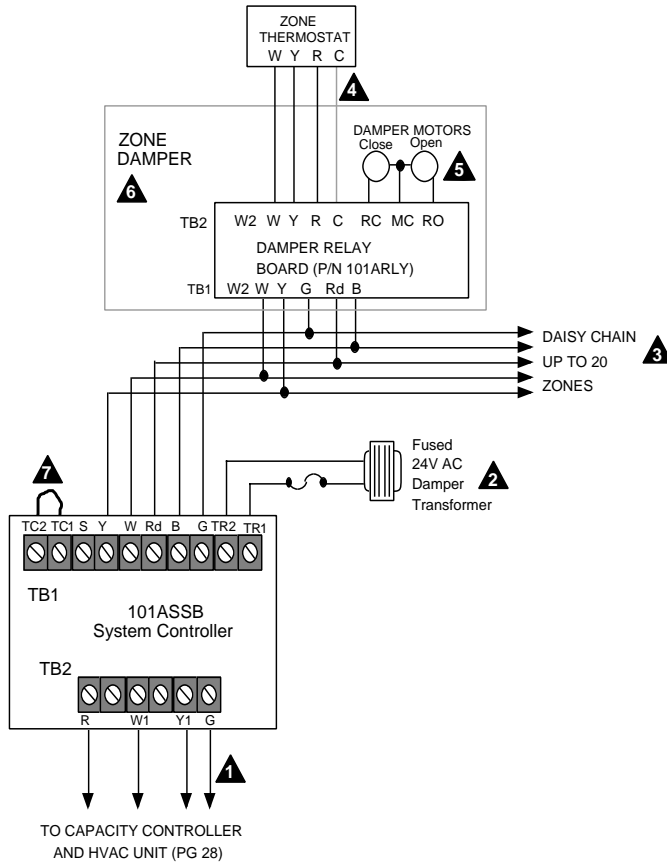

- 1 If the heater does not turn on the blower fan, a blower fan relay must be installed. See page 43.
- 2 24V damper transformer. Requires in-line fuse. See table on page 42 for sizing transformer and fuse.
- 3 Refer to page 41 for Five Wire Link wire sizing.
- 4 C terminal for hard wired electronic thermostats only.
- 5 Open motor not utilized on low pressure (spring open) dampers.
- 6 If using more than one damper per thermostat, refer to Slaving Zone Dampers section, page 23 and 44.
- 7 Do not remove factory installed jumper between TC1 and TC2. TC1 and TC2 are used for Select-Temp Zoning System only.
- 8 When using the 101ASSB controller in a heat pump application which utilizes G/E terminals, a fan relay must be installed, see page 43.

# SYSTEM 2000 CONTROLLERS – HEAT PUMP 101ACBHP

## Overview

The 101ACBHP Heat Pump Controller greatly simplifies coordination of single stage or two stage Heat Pumps with dampered zone systems. The Controller communicates to the zone dampers through a five wire link. These five wires are daisy chained to each zone damper. This simple patented wiring process eliminates home run wiring. The 101ACBHP has a built-in capacity control system which uses an LAS (included with the Controller) for capacity control. Refer to the section on Capacity Control LAS for more information.

## Operation

The Controller operates the Heat Pump using signals from each zone thermostat in the system. When heating or cooling calls are sent to the controller, it treats these calls as votes. If the majority of calls are for cooling, the Controller will operate in the cool mode. The Heat Pump will continue to operate in the cool mode until the majority of calls shift to heating or all cooling calls are satisfied. If the majority of calls are for heating, the Controller will operate in the heat mode. The Heat Pump will continue to operate in the heat mode until the majority of calls shift to cooling or all heating calls are satisfied.

*\*The reversing valve is energized depending on the O/B jumper setting.*

Second stage operation is based on the leaving air temperature of the unit. The LAS reports the discharge temperature to the Controller. Three minutes after initiating cooling, the Controller checks the LAS. If the discharge temperature is above 52 degrees, the second stage is turned on. Three minutes after initiating heating, the Controller checks the LAS. If the discharge temperature is below 114 degrees, the second stage is turned on.

The Heat Pump Controller is also set up to operate electric strip heat in the Heat Pump. The Controller monitors the air temperature leaving the Heat Pump coil. When there is a call for heat and the air leaving the coil is not above 85 degrees, the electric strip will turn on after an eight minute delay. This operation can be modified, if desired by an outdoor thermostat.

The Heat Pump Controller simplifies system wiring. The Controller terminals connect directly to the Heat Pump terminal strip. (**Heat Pump thermostats are not used for this system**). Relays, timers and other miscellaneous controls are not required.

# SYSTEM 2000 CONTROLLERS – HEAT PUMP 101AACBHP

## OPERATION (Continued)

The 101AACBHP Zonex Systems *SYSTEM 2000* Heat Pump controller has a series of lights which indicate different operations. These are labeled “Heat,” “Cool,” “Damper,” “Pump,” “Rev. Valve,” “Y1 Cool,” “Y2 Cool,” “Y1 Heat” and “Y2 Heat.” The “Heat” and “Cool” lights indicate, when illuminated, the present mode of operation. These lights will momentarily toggle to the other mode every 120 seconds when polling. Polling is when the controller checks to see how many heat and cool calls are being made. If there are no calls, the “Heat” or “Cool” light will be on based on the last operating mode. The “Damper” light indicates that a thermostat is calling and that power is being supplied to the damper motors. The “Pump” light indicates that the first stage pump is operating. The “Rev. Valve” light indicates that the reversing valve is activated, or when it flashes, that a time delay is active. The “Y1” and “Y2” Cool and Heat lights are part of the Capacity control function included on the Heat Pump Controller. The Y2 Heat or Cool LED, when illuminated, indicates the Y2 compressor has cycled OFF, because the capacity control setpoint has been exceeded. When Y1 and Y2 heat or Cool LEDs are both illuminated, the controller will initiate a 4-minute temperature cut out, with both stages cycling off.

When power is first turned on, if there are no calls for cooling or heating, the “Heat” light will be the only light illuminated, with the exception of the “Rev. Valve” light. It will also be on if jumper J1 is removed (“B” operation). When there is a cooling or heating call, the “Damper” and “Heat” or “Cool” lights will turn on.

When the “Rev. Valve” light is not indicating a time delay by flashing, it will stay illuminated only when the reversing valve is operated.

**HEAT – Reversing valve “O” Mode** – When the controller receives an initial or consecutive call for Heat, the Rev Valve LED will flash; the Heat, Damper and Pump LEDs will illuminate. The first stage heat will energize on Y1, and the Rev Valve LED will continue to flash for at least 4 minutes. After 4 minutes from Y1, if the supply temperature is 95° or less, Y2 will energize and the Rev Valve LED will go OFF (Heat “B” mode will change the flashing Rev Valve LED to ON when Y2 energizes). The auxiliary heat will energize 4 minutes after Y2 and when the supply air temperature is 85° or less.

**COOL – Reversing Valve “O” Mode** – When the controller receives an initial or consecutive call for Cool, the Rev Valve LED will flash; the

Cool, Damper and Pump LEDs will illuminate. The first stage cool will energize on Y1 and O/B with the Rev Valve LED flashing for 8 minutes. After 8 minutes from Y1, if the supply air temperature is 60° or higher, Y2 second stage of cooling will energize. The Rev Valve LED will change from flashing to steady ON. (Cool “B” mode for Rev Valve LED will change from flashing to OFF after Y2 energizes.)

**AUTO CHANGEOVER** – If an existing mode is overridden by an opposite majority, the existing call will remain in operation for 4 minutes, and then the controller will go into a 2 minute purge with the existing dampers staying open. After the purge cycle has timed out, the system blower cycles OFF (when in the auto mode). The controller goes into a 2 to 4 minute delay, switching to the opposite mode, with the dampers making the opposite call opening. Y1 and Y2 are not energized during this delay. After this final delay times out, the controller energizes Y1 in the opposite mode.

If all zones satisfy, the “Pump” and “Damper” lights will go out. The “Heat” or “Cool” lights will be on based on the last mode of operation.

If your system includes auxiliary heat, it will be activated by the “W” terminal on the *SYSTEM 2000*'s Heat Pump Controller. Auxiliary heat will be activated when the following conditions are met. The “Heat” and “Damper” lights are on indicating a heat call; the “Pump” light is on and the “Rev. Valve” light is not flashing, indicating that first and second stage are activated; four minutes after the “Rev. Valve” light stops flashing the auxiliary heat will be activated if the leaving air temperature is below the Electric Heat setpoint (factory set at 85 degrees). The time delay before bringing on the auxiliary heat gives the second stage time to raise the leaving air temperature over 85 degrees. Even if the system is single stage, the controller will still delay the electric heat until after the second stage time delay is satisfied.

The reversing valve is controlled by the “O/BL” terminal. This terminal should be connected to the Heat Pumps terminal strip according to the unit manufacturers recommendations. Jumper J1 on the *SYSTEM 2000* Heat Pump board needs to be adjusted to operate with the different manufacturers designs. The Heat Pump board is shipped from our factory ready to operate a heat pump unit which requires the “O” wire to energize the reversing valve in cooling. If the reversing valve needs to be activated for the “BL” terminal, jumper J1 needs to be removed from the Controller board. Refer to the Heat Pump Controller drawing on the previous page for the location of jumper “J1”. Remove the jumper from the board to activate the reversing valve using the “BL” terminal.

**Warning:** For heat pumps using standard gas/electric thermostats, do not use the 101AACBHP System Controller. Instead, use the 101ASSB System Controller and the CAPL-2 Capacity Controller.



# SYSTEM 2000 CONTROLLERS – HEAT PUMP 101AACBHP

## OPERATION SUMMARY TABLE (EFFECTIVE HPC V1.04 8/02)

POWER UP, NO CALLS:		CALL (HEAT/COOL):		1ST STAGE	2ND STAGE	AUX. HEAT
<b>STATUS LIGHTS:</b>		<b>STATUS LIGHTS:</b>		0	DELAY IN MINUTES 4*	8
DAMPER	OFF	DAMPER	ON	ON	ON	ON
REV. VALVE	NOTE 1	REV. VALVE	FLASH	ON FOR HEAT	NOTE 1 ON FOR HEAT	NOTE 1 ON FOR HEAT
HEAT*	ON	HEAT	ON FOR HEAT	ON FOR HEAT	ON FOR HEAT	ON FOR HEAT
COOL*	OFF	COOL	ON FOR COOL	ON FOR COOL	ON FOR COOL	ON FOR COOL
PUMP	OFF	PUMP	ON	ON	ON	ON
<b>TB2:</b>		<b>TB2:</b>				
Y1	OFF	Y1	ON	ON	ON	ON
Y2	OFF	Y2	OFF	ON	ON	ON
G	OFF	G	ON	ON	ON	ON
W	OFF	W	OFF	OFF	OFF	NOTE 2
O/BL	NOTE 1	O/BL	NOTE 1	NOTE 1	NOTE 1	NOTE 1

MODE CHANGE:		1ST STAGE		2ND STAGE	AUX. HEAT	
		DELAY IN MINUTES				
		4	8	10	12	
<b>STATUS LIGHTS:</b>		O	4	8	10	12
DAMPER	ON	ON	ON	ON	ON	ON
REV. VALVE	↑	FLASH	FLASH	NOTE 1	NOTE 1	NOTE 1
HEAT*	ON FOR HEAT	ON FOR HEAT	ON FOR HEAT	ON FOR HEAT	ON FOR HEAT	ON FOR HEAT
COOL*	ON FOR COOL	ON FOR COOL	ON FOR COOL	ON FOR COOL	ON FOR COOL	ON FOR COOL
PUMP	OFF	OFF	ON	ON	ON	
<b>TB2:</b>						
Y1	OFF	OFF	ON	ON	ON	
Y2	OFF	OFF	OFF	ON	ON	
G	OFF	OFF	ON	ON	ON	
W	OFF	OFF	OFF	OFF	NOTE 2	
O/BL	NOTE 1	NOTE 1	NOTE 1	NOTE 1	NOTE 1	

**\*NOTE:**  
**Cool:** Y2 delay on make 8 min.

**Heat:** Y2 delay on make 4 min.

NOTE 1: On if: a) In cool mode and reversing valve set for "O" operation (J1 jumper installed).  
b) In heat mode and reversing valve is set for "BL" operation (J1 jumper removed).

NOTE 2: On when in heat mode and supply air temperature below Electric Heat setpoint. Heat, Cool, and Fan switches in AUTO position. Capacity Controller lights off. Delay times are approximate.

\*Momentarily toggles to opposite mode every 120 seconds.

## WIRING

### NOTES:

- 1 Refer to page 41 for 5 wire link wire sizing.
- 2 24V damper transformer. Requires in-line fuse. See table on page 42 for sizing transformer and fuse.
- 3 C terminal for hardwired electronic thermostats only.
- 4 J1 Reversing Valve Selection Jumper. Leave jumper in place to energize reversing valve in cool mode, "O" mode. Remove jumper to energize in heat mode, "B" mode. J2 is not used for System 2000.
- 5 If the heat pump does not include an outdoor thermostat, it is recommended that the "W" wire to the unit is run thru an optional outdoor thermostat with a manual override switch.
- 6 Do not remove the jumper wire from TC1 and TC2. Used for Select-Temp Zoning System only.
- 7 Open motor not utilized on low pressure (spring open) dampers.
- 8 If using more than one damper per thermostat, refer to Slaving Zone Dampers section, pages 23 and 44.

### NOTE:

If the Heat Pump system does not have rev. valve inputs, use the 101ASSB (Gas/Electric Controller).

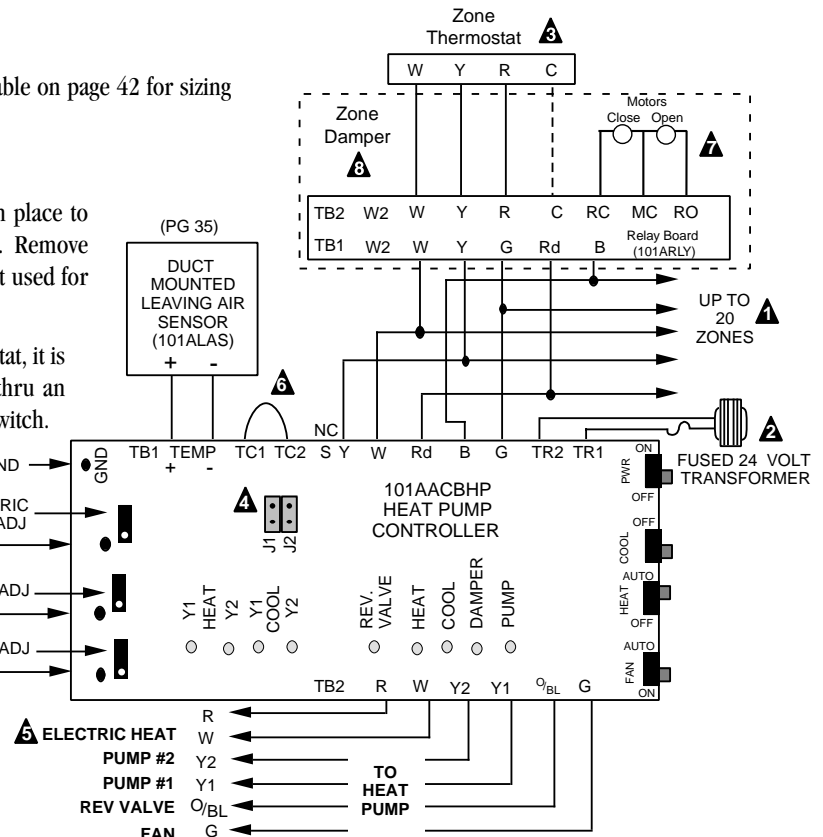

# SYSTEM 2000 SYSTEM STARTUP

Make sure the correct size fuse is installed in-line with the transformer powering the Controller.

## For both Gas/Electric and Heat Pump Controllers

1. These system tests are to be done with all wiring to the air conditioning unit disconnected.
  - A. Be sure that the power switch to the Controller is in the "OFF" position. For **Gas/Electric** remove "R," "W1," "Y1" and "G" wires from Terminal Strip 2 labeled (TB2).
  - B. Be sure that the power switch to the Controller is in the "OFF" position. For **Heat Pumps** remove "R," "W," "Y2," "Y1," "O/BL" and "G" wires from Terminal Strip 2 labeled (TB2).
2. Check wiring of the 5 wire link to the dampers. All connections must be made color to color.
3. If you are not using Zonex Systems supplied zone thermostats, check each one to make sure it is an auto changeover type stat. Turn all thermostats to the OFF position. Check the Controller "HEAT" and "COOL" switches to be sure that both are in the "OFF" position. The "FAN" switch should be in the "AUTO" position. Observe the fuse on the Controller Board and transformer. Turn the power switch to "ON." If the fuse blows, there is a wiring problem. If the fuse does not blow, turn the "HEAT" switch to "AUTO" and "COOL" switch to "AUTO." If the fuse blows at any of these steps, find and repair the short in the wiring.
4. If the system is operating normally, the Heat light should be on for the 101ASSB, and 101AACB-HP. Set the "HEAT" switch to "OFF". Check the first zone by turning it on and setting it to call for cooling. If the call is received by the Controller, the "Damper" and "Cool" lights will turn on. If the lights come on, turn off the first stat and the "Damper" light should turn off. Test each stat this way to be sure that each one is capable of communicating with the Controller, and able to start and stop the air conditioner.
5. After cooling calls are tested, turn the cooling switch to "OFF" and set the heating switch to "AUTO". Set the first zone to call for heat. If the call is received by the Controller, "Damper" and "Heat" lights will turn on. Test each thermostat to be sure that each properly communicates with the Controller for the heating sequence.
6. After all zones have been checked, turn the ON/OFF switch at the System Controller to OFF.
7. Before wiring the System Controller to your A/C unit or furnace, check the relays with a volt meter (set on 200 Ohms). Be certain no continuity exists on the A/C unit terminal connections at the System Controller. Check between each terminal to the "R" terminal. There should be no continuity between the terminals. (If you do show continuity, your System Control board should be replaced.)
8. If no continuity exists from the test detailed above, connect the terminal to the A/C unit and the System Controller. Be certain all thermostats are now in the "OFF" position.
9. Turn the power switch to "ON" and the "HEAT" and "COOL" switches should be set to "AUTO". Initiate a call for cooling from only one stat. After a time delay, both compressor and fan should be running. Turn off the cooling and initiate a heating call, (you may experience up to a 4 minute time delay). The heat should come on and after a short time delay the fan will be operated by the internal controls of the unit. On the Heat Pump controller, eight minutes on the initial start of CAPL-2 after stage one starts, the LAS or capacity control will control second stage operation.
10. After completing the system check and startup procedure, set the system up for normal operation.

*NOTE:* "Heat" and "Cool" Led indicators will toggle every two minutes to check opposite mode callers, regardless of heat and cool switch positions.

# SYSTEM 1000

System 1000 Zone Control enables a single HVAC unit to be controlled by up to seven zone (room) thermostats. System 1000 is a manual changeover system. This means that the mode of operation (heat/cool)

is manually selected. **For auto changeover capability select Zonex Systems System 2000.**

**CONCEPTUAL DRAWING ONLY**  
Refer to System 1000 Switching Center Section for Wiring Information.

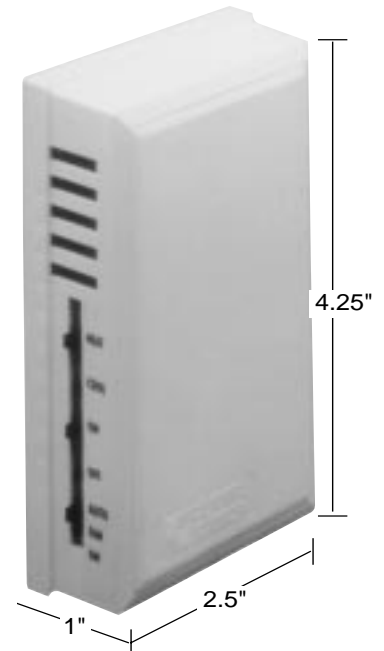
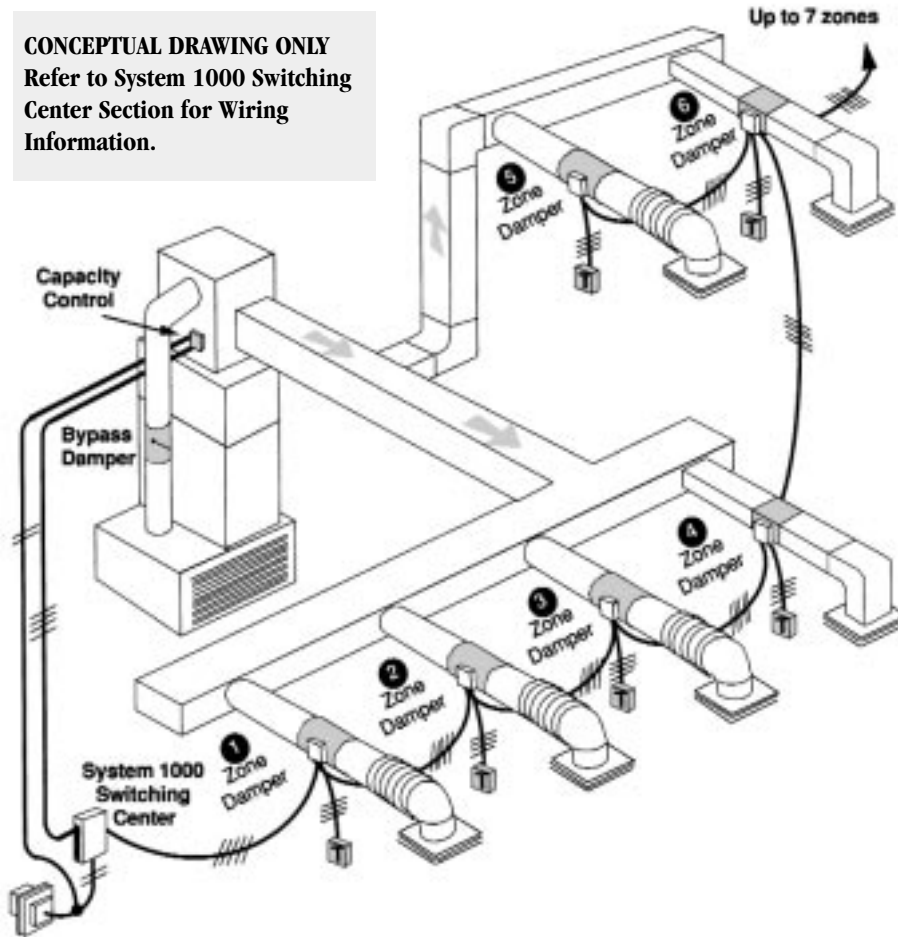

**System 1000  
Switching Center**

## SYSTEM OPERATION

The user manually selects the mode (heat/cool) at the Switching Center. If any zone thermostat calls for the mode selected, the green call light turns on at the Switching Center, the HVAC/heat pump unit turns on, and all non-calling zone dampers close.

Once all zones are satisfied, the green call light turns off, the HVAC/heat pump unit shuts off and all dampers open. If the Switching Center fan switch is ON, the fan will continue to run to allow ventilation in all zones.

The Capacity Controller independently monitors the supply air temperature to prevent coil freeze up or overheating.

The Bypass damper will independently bypass any supply air not needed back to the return duct.

## System 1000

### Zonex Systems Supplied Components

Switching Centers.....	Pages 11-14
Zone Thermostats .....	Pages 16-17
Zone Dampers .....	Pages 18-23
Bypass Dampers .....	Pages 23-27
Capacity Controllers.....	Pages 28-41

## System 1000

### Field Supplied Components

Thermostat Wire.....	Page 41
24V Transformer(s) and Fuse.....	Page 42

# SYSTEM 1000 – COMPONENT SELECTION GUIDE

Manual Changeover for 2 to 7 Zones

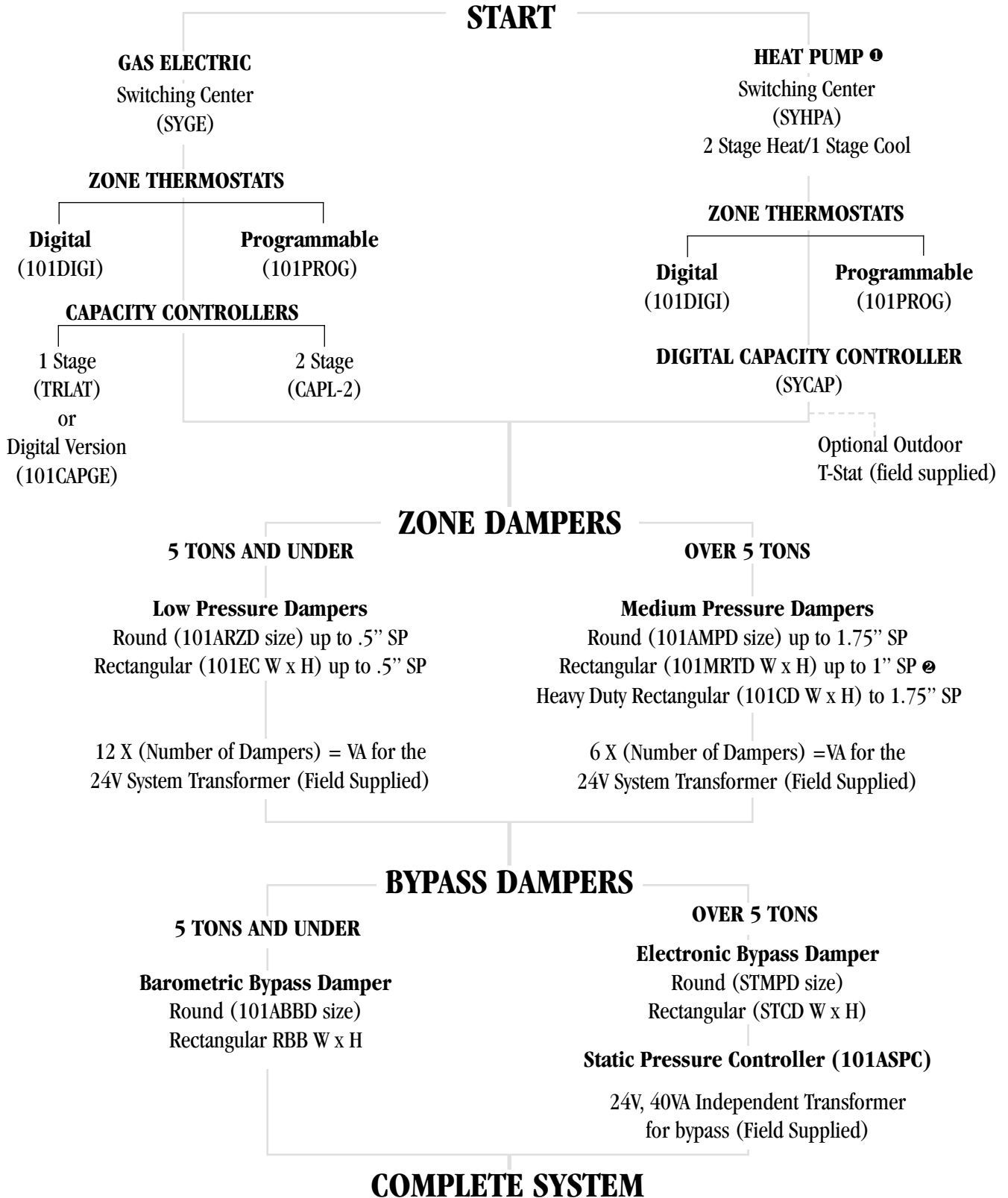

① Some Heat Pumps utilize Gas/Electric thermostats. For this type of Heat Pump, use the Gas/Electric parts selection and field modify the capacity control heat cutoff setpoint to 118° F.

② Use heavy duty rectangular dampers on systems of 7.5 tons or larger

# SYSTEM 1000 SWITCHING CENTERS – GAS/ELECTRIC SYGE

## OVERVIEW

The SYGE Switching Center is a manual changeover, Gas/Electric System Controller. It can control up to 7 zone thermostats. Its function is to look for calls from the zone thermostats for the mode (heat/cool) selected. If a call is received, it sends a signal to close the dampers of all zones not calling and sends a signal to the HVAC unit to energize heating or cooling.

The Mode, Power and Fan control switches are located at the Switching Center. The Switching Center should be placed in a location that provides easy access to these switches.

The Switching Center is used in conjunction with a Capacity Controller. The Capacity Controller protects the evaporator coil from freezing and the heat exchanger from overheating. The Capacity Controller also controls staging for multistage HVAC systems. Refer to the Capacity Controller section (pg. 28) for more information.

## OPERATION

The user manually selects the mode (heat/cool) at the Switching Center.

**Heat mode** – If any zone thermostat calls for heat, electrical current flows in WD. The Switching Center senses this current, turns on the green Call light, energizes RD (RD made to GD) which tells the dampers of all zones not calling to close and energizes W (W made to R) which tells the HVAC unit to turn on heat.

**Cool mode** – If any zone thermostat calls for cool, electrical current flows in YD. The Switching Center senses this current, turns on the green Call light, energizes RD (RD made to GD) which tells the dampers of all zones not calling to close, and energizes Y and G (Y and G made to R) which tells the HVAC unit to turn on cooling and the indoor blower fan.

**No calls** – When no thermostats are calling, the green Call light is off, RD is not energized so all dampers are open, and W, Y are not energized so the HVAC unit is off. If the FAN switch is ON, then G is energized (G made to R), and the indoor blower fan will run. This allows ventilation in all zones.

## COMPONENTS

- 5 Wire Link Terminals** – Daisy chain wires to zone dampers.  
 YD – Cool call input signal. Current flows in this terminal when Mode switch at COOL, Power switch ON and thermostat calling for cool.  
 WD – Heat call input signal. Current flows in this terminal when Mode switch at HEAT and thermostat calling for heat.  
 BD – 24V return. Same as TR2.  
 GD – 24V hot. Same as TR1.  
 RD – Unit on output signal. Energized (RD made to GD) when Switching Center acknowledges thermostat call. See 7.
- Transformer Terminals** – 24V AC transformer terminals. This transformer powers the dampers, thermostats and Switching Center. It does not power the HVAC unit. That power comes from terminal R; see 3.
- HVAC Unit Terminals** – Connect to HVAC unit via Capacity Controller. See Capacity Controller section for wiring information.  
 W – Heat enable. Energized (W made to R) when Switching Center acknowledges a heat call. See 7.  
 Y – Cool enable. Energized (Y made to R) when Switching Center acknowledges a cool call. See 7.  
 R – HVAC unit 24V power.  
 G – Fan enable. Energized when FAN switch is at ON position or when FAN switch is at AUTO position and Switching Center acknowledges a cool call. See 7.
- Mode Switch** – Selects mode (heat/cool) to run system. Switching Center will only respond to thermostats calling for mode selected.

- Power Switch** – When OFF the Switching Center will not respond to thermostat calls. Power remains to all dampers and thermostats. The indoor blower fan will run if fan switch is on.
- Fan Switch** – Controls the indoor blower fan (G).  
 AUTO – Indoor blower fan turns on when air conditioner is on.  
**Note:** In heat mode, furnace controls indoor blower fan.  
 ON – Indoor blower fan continuously on as long as Power switch is ON.
- Call Light** – On when Switching Center responds to a calling thermostat.

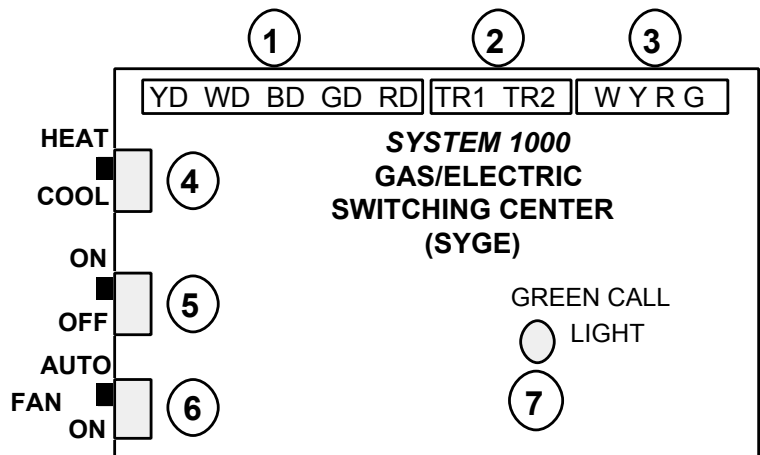

# SYSTEM 1000 SWITCHING CENTERS – GAS/ELECTRIC SYGE

## WIRING

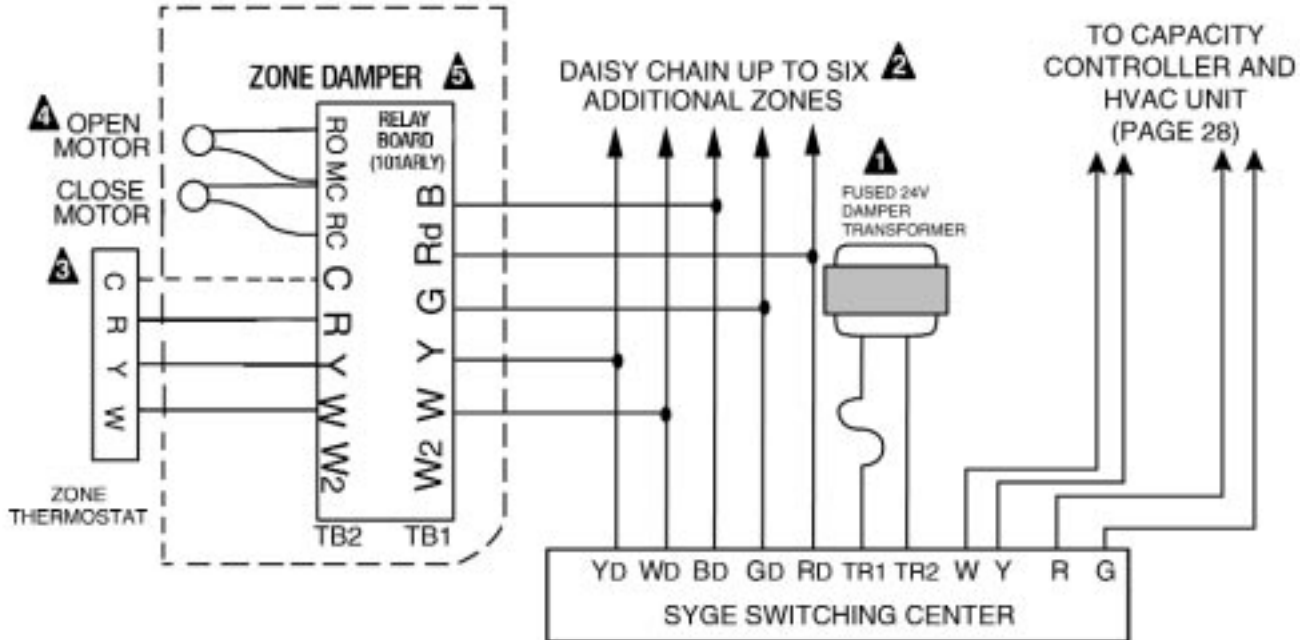

### NOTES:

- 1 24V damper transformer. Requires in line fuse. See table on page 42 for sizing transformers and fuse.
- 2 Refer to page 41 for five wire link wire sizing.
- 3 C terminal for hard wired electronic thermostats only.
- 4 Open motor not utilized on low pressure (spring open) dampers.
- 5 If using more than one damper per thermostat, refer to Paralleling Zone Dampers section, pages 23 and 44.

### SIMPLIFIED SCHEMATIC, SYGE

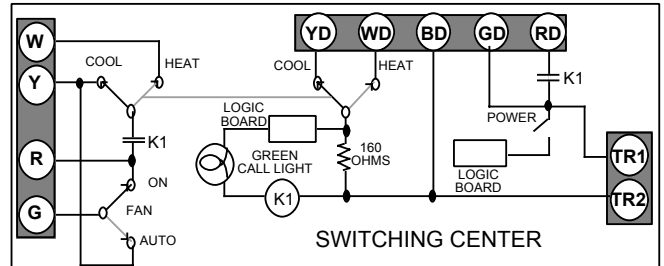

# SYSTEM 1000 SWITCHING CENTERS – HEAT PUMP SYHPA

### SIMPLIFIED SCHEMATIC, SYHPA

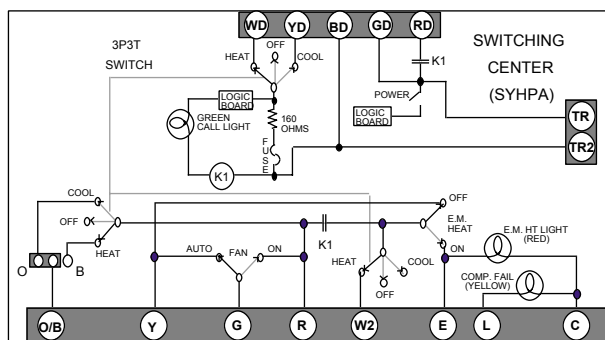

### OVERVIEW

The SYHPA Switching Center is a manual changeover, single stage cool, two stage heat, heat pump System Controller. It can control up to 7 zone thermostats. Its function is to look for calls from the zone thermostats for the mode (heat/cool) selected. If a call is received, it sends a signal to close the dampers of all zones not calling and sends a signal to the heat pump unit to energize heating or cooling.

The Switching Center is used in conjunction with a SYCAP Capacity Controller. The SYCAP cycles the heat pump on and off to maintain the leaving air temperature within a set range. Refer to the SYCAP in the Capacity Controller section (pg. 33) for more information.

# SYSTEM 1000 SWITCHING CENTERS – HEAT PUMP SYHPA

The Mode, Power, Fan and Emergency Heat control switches are located at the Switching Center. The Switching Center should be placed in a location that provides easy access to these switches.

**NOTE:** If your heat pump is controlled by a gas/electric thermostat, use an SYGE Switching Center. See SYGE Switching Center section, pg. 3.

## OPERATION

The user manually selects the mode (heat/cool) at the Switching Center.

**Heat mode** – With the Mode switch set to HEAT, Fan switch set to AUTO, EM HT switch set to OFF and Power switch set to ON, if any zone thermostat calls for heat, electrical current flows in WD. The Switching Center senses this current, turns on the green Call light, energizes RD (RD made to GD) which tells the dampers of all zones not calling to close and energizes Y, W2 and G (Y, W2 and G made to R). G turns on the indoor blower fan. Y controls the heat pump compressor and W2 controls auxiliary heat. Y and W2 are further controlled by the SYCAP Capacity Controller which makes and breaks Y and W2 to maintain a minimum and maximum leaving air temperature. See SYCAP under Capacity Controller section for further information. The reversing valve is energized (B made to R) if the reversing valve jumper is set to B.

**Cool mode** – With the Mode switch set to COOL, Fan switch set to AUTO, EM HT switch set to OFF and Power switch set to ON, if any zone thermostat calls for cool, electrical current flows in YD. The Switching Center senses this current, turns on the green Call light, energizes RD

(RD made to GD) which tells the dampers of all zones not calling to close and energizes Y, and G (Y and G made to R). G turns on the indoor blower fan. Y controls the heat pump compressor. Y is further controlled by the SYCAP Capacity Controller which makes and breaks Y to maintain a minimum leaving air temperature. See SYCAP under Capacity Controller section for further information. The reversing valve is energized (O made to R) if the Reversing Valve jumper is set to O.

**No calls** – When no thermostats are calling, the green Call light is off, RD is not energized so all dampers are open, and W2, Y are not energized so the HVAC unit is off. If the FAN switch is ON then G is energized (G made to R) and the indoor blower fan will run. This allows ventilation in all zones.

**Emergency Heat** – With the Mode switch set to HEAT, Fan switch set to AUTO, EM HT switch set to ON and Power switch set to ON, if any zone thermostat calls for heat, electrical current flows in WD. The Switching Center senses this current, turns on the green Call light and red Emergency Heat light, energizes RD (RD made to GD) which tells the dampers of all zones not calling to close and energizes E (E made to R). What E is wired to depends on the make of your heat pump. Refer to the SYHPA wiring diagram for further information.

**Note:** Do not leave the Emergency Heat switch set to ON when the Mode switch is set to COOL. Doing so will energize E (turning on emergency heat) when a thermostat makes a cool call.

## COMPONENTS

- 5 Wire Link Terminals** – Daisy chain wires to zone dampers.  
WD – Heat call input signal. Current flows in this terminal when Mode switch is at HEAT and thermostat is calling for heat.  
YD – Cool call input signal. Current flows in this terminal when Mode switch is at COOL, Power switch is ON and thermostat is calling for cool.  
BD – 24V return. Same as TR2.  
GD – 24V hot. Same as TR1.  
RD – Unit on output signal. Energized (RD made to GD) when Switching Center acknowledges thermostat call. See 9.
- Transformer Terminals** – 24V AC transformer terminals. This transformer powers the dampers, thermostats and Switching Center. It does not power the HVAC unit. That power comes from terminal R; see 3.
- Heat Pump Unit Terminals** – Connect to Heat Pump unit via SYCAP Capacity Controller.  
O/B – Reversing Valve terminal. Energized (O/B made to R) in heat mode when O/B jumper is at B. Energized in cool mode when O/B jumper is at O.  
Y – Compressor enable. Energized (Y made to R) when Switching Center acknowledges a heat or cool call and Emergency Heat Switch OFF.  
G – Fan enable. Energized when FAN switch is at ON position or when FAN switch is at AUTO position, Emergency Heat Switch is OFF and Switching Center acknowledges a heat or cool call.

R – Heat Pump unit 24V power.

E – Emergency Heat enable. Energized (E made to R) when Switching Center acknowledges a heat call and Emergency Heat switch is ON. See 6 and 9.

W2 – Auxiliary Heat enable. Energized (W2 made to R) when Switching Center acknowledges a heat call and Emergency Heat switch is OFF. Sends signal to SYCAP.

L – Compressor fail flag input terminal. If feature is provided by Heat Pump, when L is energized (L made to R), red light DL3 is illuminated to signal compressor is not working.

C – Heat Pump unit 24V power return.

- Mode Switch** – Selects mode (HEAT/OFF/COOL) to run system. Switching Center will only respond to thermostats calling for mode selected.
- Fan Switch** – Controls the indoor blower fan (G) when the Emergency Heat switch is OFF.  
AUTO – Indoor blower fan turns on when Heat Pump is on.  
ON – Indoor blower fan is continuously on as long as Power switch is ON.
- Emergency Heat** – Disables compressor (Y) and blower fan (G) and energizes E (E made to R). This tells the Heat Pump to turn on auxiliary heat. Should only be used when Mode switch is in HEAT. If used when mode switch is in COOL, auxiliary heat will turn on when there is a cool call.

# SYSTEM 1000 SWITCHING CENTERS - HEAT PUMP SYHPA

7. **Reversing Valve Selection Jumper** – Configures Switching Center to energize reversing valve in cool mode or heat mode. Place on O and center pin to energize reversing valve in cool mode. Place on B and center pin to energize in heat mode.
8. **Fuse** – 1/10 amp. Protects WD and YD terminals.
9. **Status Lights** –  
DL1 – Call light, green. On when Switching Center responds to a calling thermostat.  
DL2 – Compressor fail, yellow. On when L terminal is energized (L made to R). Indicates heat pump compressor is not functioning.  
DL3 – Emergency Heat, red. On when E terminal is energized (E made to R).
10. **Power Switch** – When OFF the Switching Center will not respond to thermostat calls. The indoor blower fan will run if Fan switch is ON. Power remains to all dampers and thermostats.

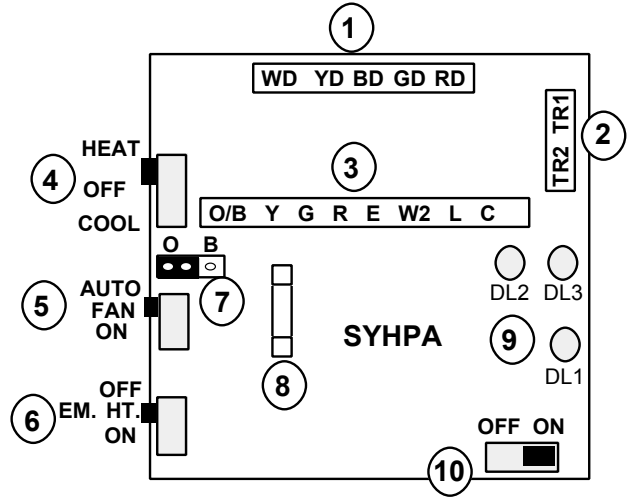

## WIRING

1. Open motor not utilized on low pressure (spring open) dampers.
2. C terminal for hardwired electronic thermostats only.
3. 24V damper transformer. Requires in-line fuse. See table on page 42 for sizing transformer and fuse.
4. Refer to page 41 for Five Wire Link wire sizing.
5. If the heat pump does not include an outdoor thermostat, it is recommended that the “W2” wire to the heat pump unit is run thru an optional outdoor thermostat with a manual override switch.
6. If using more than one damper per thermostat, refer to paralleling zone dampers, pages 23 and 44.
7. If the heat pump does not have an emergency heat terminal, connect “E” of Switching Center to auxiliary heat terminal of heat pump. If the heat pump does not turn on the indoor blower fan in emergency heat mode, add blower fan relay as shown below.

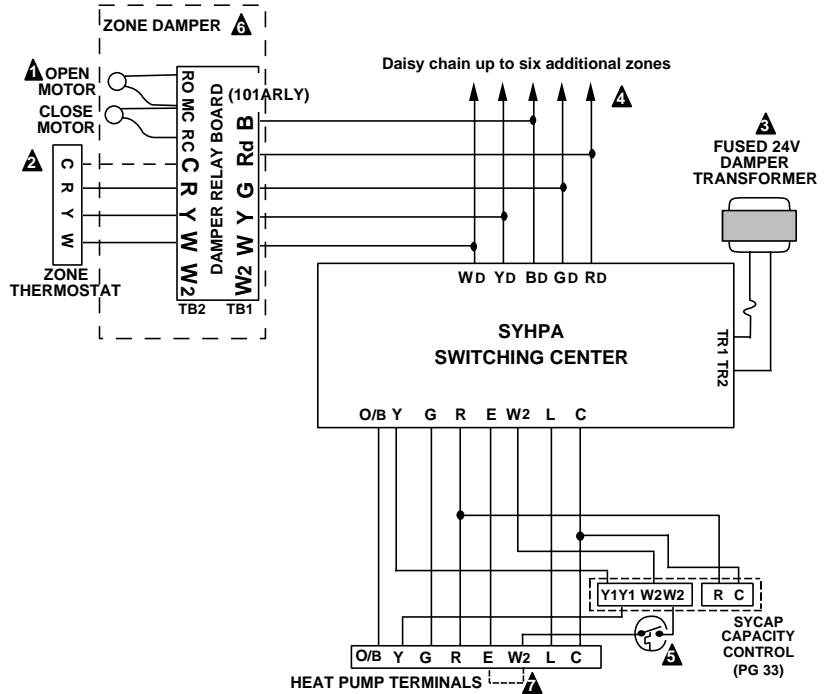

## EMERGENCY HEAT BLOWER FAN RELAY

If the heat pump does not energize the indoor blower fan when emergency heat is energized, add relay K1 as shown. Relay K1 is a 24VAC SPDT relay.

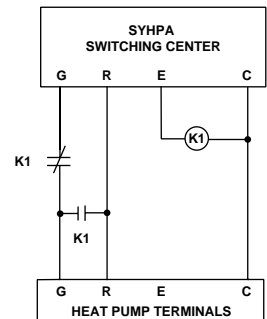



# SYSTEM 1000 STARTUP

When all wiring is completed to the dampers and the gas electric/heat pump unit, the following tests should be made:

- ✓ Disconnect the **R** wire from the Switching Center.
- ✓ Check to be sure that there is 24 volt power between terminals **TR1 & TR2**.
- ✓ Set all thermostat switches to the OFF position.
- ✓ Set the Switching Center in the HEAT mode.
- ✓ Set the Switching Center ON/OFF switch to ON.

The green call light should be off at the Switching Center. If it is on, there is a thermostat calling or the **WD** wire is shorted.

- ✓ Check all of the thermostats, if they are off, remove the **WD** wire from the Switching Center. The green light should go off. If it does, find the short in the five wire link before re-connecting it. If the green light does not turn on, test each thermostat, one at a time. Turn on one thermostat, set it to call for heating, and the green light on the Switching Center should turn on. When you set this same thermostat for no heat, the green light at the Switching Center should turn off. Test each thermostat in this manner to be sure all thermostats are properly wired.

Now, set the Switching Center in the COOL mode.

If the green light turns on with all thermostats off, there is a short in the **YD** wire. Correct the problem before proceeding.

Repeat the test of each thermostat in the cool mode. When a thermostat is calling, the green call light will turn on. Turning this thermostat off will turn off the green call light at the Switching Center.

## GAS/ELECTRIC SYGE

Turn the ON/OFF switch off and reconnect the **R** wire. Be sure that all thermostats are off. Turn the ON/OFF switch ON. Decide if you want to test the heating or cooling system and set the HEAT/COOL switch to the desired position.

If you have set the switch to COOL, set one thermostat to call for cooling. The green light will turn on and the cooling system compressor and indoor fan will turn on. If it does not, check wiring between the Switching Center and the unit.

If you have set the switch to HEAT, set one thermostat to call for heat. The green light will turn on and the furnace should start. The fan will start when the time delay or bonnet control turns it on. If the system does not turn on, check the wiring between the Switching Center and the furnace.

The Switching Center controls the furnace and air conditioner with relay contacts. The Switching Centers R,Y,W&G terminals operate exactly like a four wire thermostat. Trouble shooting the heating and air conditioning equipment should be handled as though the Switching Center is a four wire thermostat.

## HEAT PUMP (SYHPA) with the SYCAP

Check that the fuse on the SYHPA has not blown. If it has, check for shorts on the **WD** and/or **YD** wires on the five wire link and replace the 1/10 amp fuse.

Turn the POWER switch on the SYHPA and SYCAP OFF: Check all thermostats to be sure that they are off. Reconnect the **R** wire at the SYHPA. Check to be sure that the O/B jumper on the SYHPA is in the correct position for the heat pump. Turn the POWER switch on the SYHPA to ON.

To test the COOL mode, set the HEAT/COOL switch on the SYHPA to the COOL position. Set only one thermostat to call for cooling. The green call light on the SYHPA should turn on and the compressor will run. The indoor fan will start with the compressor. If the compressor or fan do not start, check the wiring between the SYHPA and the Heat Pump.

To test the HEAT mode, turn the POWER switch on the SYHPA to OFF. Turn all thermostats off. Set the MODE switch on the SYHPA to HEAT and then turn the POWER switch ON. Set one thermostat to call for heat. The green call light will turn on at the SYHPA and the compressor will turn on in the heat mode. The fan will turn on with the compressor. If the fan or compressor does not turn on, check the wiring.

When yellow DL2 is lit, there is a heat pump compressor failure (if “L” terminal has been wired).

When the “EM HT” switch is set to ON, the SYHPA will never power the “Y” or “G” terminal and will power the “E” terminal during a call. While the “EM HT” switch is set to ON, the red light labeled DL3 will turn on if there is a call. To test the Auxiliary/Electric heat, see the unit manufacturers wiring diagrams and instructions.

## SYCAP and Auxiliary/Electric Heat

To test the Auxiliary/Electric heat, turn the SYCAP switch ON. If the display begins to toggle between “E” and “157”, the factory installed temperature sensor or its wiring to terminals ± is open. If the display toggles between “E” and “32”, the temperature sensor is shorted. Check connections + and – and the wire holding the sensor in the plenum for shorts.

During normal startup the supply air temperature should be displayed. Unless modified at this time, the SYCAP will operate at factory cut-out setpoints of 118 degrees F. for heat and 48 degrees F. for cooling. To modify these cut-out setpoints see “Determine the existing cut-out setpoints on a CAP” in the Capacity Control section of this manual.

To test the Auxiliary/Electric heat disconnect the Y wire at the SYCAP or SYHPA. Set one stat to call for heat. If the supply air temperature is below the electric heat cut-in setpoint, and after a four minute time delay, DL2 and the Auxiliary/Electric heat will turn on.

After testing the SYCAP, replace the Y wire for proper heat pump operation.

**Note:** At temperatures below 38°F and above 125°F (heat pumps), the display will toggle between “E” and the supply duct temperature. This is normal operation and provisions have been made to allow the heating and cooling to operate.

# ZONE THERMOSTATS

Each zone requires a zone thermostat. This thermostat can be digital, mechanical, or programmable. All three types are available. Zonex Systems thermostats have been specifically designed to work with Zonex Systems Zone Control systems. Attempting to use another manufacturer's thermostat may create compatibility problems and cause nuisance calls. For trouble free installation, use only Zonex Systems supplied thermostats.

## Digital Thermostats

Zonex Systems makes two Digital Thermostats for the System 1000/2000: **101DIGI** – a single stage thermostat that can be used whenever auxiliary zoned heating is not required.

**101DIGITS** – a single stage cool, two stage heat thermostat. It should be used when auxiliary zoned heating is needed.

**101DIGI:** This is a digital, dual setpoint, single stage zone thermostat, accurate to within one degree. The 101DIGI is auto changeover, is non power robbing, and is designed with a non-volatile memory to retain all programmed setpoints. The stat is operated by two push buttons to review and modify heat and cool setpoints. To avoid unauthorized setpoint modifications, the 101DIGI has locking setpoint capability. There is also a zone On/Off switch. Under the cover there is a green and red light. When the green light is on the stat is calling for cooling. When the red light is on the stat is calling for heat. Following any call, the stat is designed with a two-minute minimum run time to prevent short cycling. It can be used with any of the System 1000/2000 Controllers. This thermostat can be ordered with a remote sensor (101DIGIRS). The 101DIGI Dimensions are: 2-7/8"W x 4-1/2"H x 1"D, the color is off white. Requires four thermostat wires for installation.

**101DIGITS** This is an auto changeover, electronic zone thermostat with auxiliary heat output. This dual setpoint thermostat has a large digital readout which displays current room temperature. Under the cover there are two red lights and one green light. When the green light is on, the thermostat is calling for cooling. When the red light labeled "D-1" is on, the the stat is calling for first stage heat. When the the red light labeled "HT2" is on, the stat is calling for second stage heat. This zone thermostat is designed for zones that require supplemental heat. This thermostat can be ordered with a remote sensor by adding RS to its part number. 101DIGITS dimensions are 2 7/8" W x 4 1/2" H x 1" D. Installation requires five wires.



### 101DIGI Thermostat Operation

Each digital thermostat has an "ON" / "OFF" switch located at the bottom. Typically, this thermostat should always be in the "ON" position. When the room is unoccupied, use this switch to take the zone out of your system by sliding it to the left to turn it off. When the room is occupied slide the switch to the right to turn it on. Assign the Heating and Cooling Setpoints desired by using the following instructions:

## 1. Determine the existing Set-points:

A. To determine the existing Heat Setpoint, press and hold the top button marked  $\wedge$  until the letter "H" appears and then release. The current heat setpoint will be displayed following the letter "H" (If the button is held down too long the Heat Setpoint will begin to increase). Approximately two seconds after the button is released the current room temperature will be redisplayed.

B. To determine the existing Cool Setpoint press and hold the lower button marked  $\vee$  until the letter "C" appears and then release. The current Cool Setpoint will be displayed following the letter "C" (If the button is held down too long the Cool Setpoint will begin to decrease). Approximately two seconds after the button is released the current room temperature will be redisplayed.

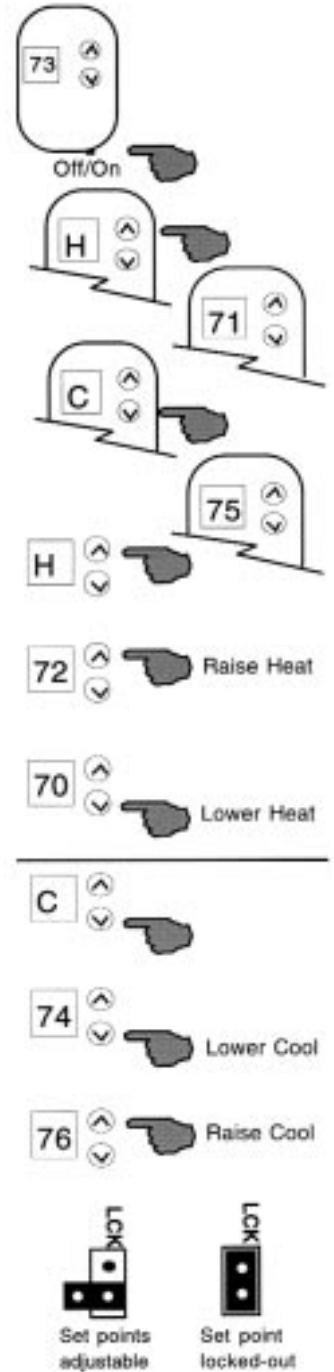

## 2. Modifying the Setpoints:

A. To change the Heat Setpoint, press and hold the top button until the Heat Setpoint is displayed. Continue to press this button (the up button  $\wedge$ ) to increase the Heat Setpoint or press and hold the bottom button  $\vee$  to reduce the Heat Setpoint to your desired comfort level in this room.

B. To change the Cool Setpoint, press and hold the lower button  $\vee$  until the Cool Setpoint is displayed. Continue to hold this button to lower the Cooling Setpoint or press the top button  $\wedge$  to raise the Cool Setpoint to your desired comfort level in this room.

**Set up all of the zone thermostats in this way to provide room by room comfort control.**

## ZONE THERMOSTATS

### 3. Locking the Set points:

To avoid unauthorized setpoint modifications, the 101DIGI has locking setpoint capability. After the heat and cool setpoints have been selected, use the jumper located under the cover near the middle of the board labeled LCK to lock the setpoints. Slide the jumper over both terminals as shown in the diagram above. This will lock the setpoints in place. To modify the setpoints, the jumper must be moved to the adjustable position.



**DIGICOM:** The DIGICOM auto changeover, communicating thermostat is used exclusively in ZonexCommander thermal management systems. Using a computer and the ZonexCommander software, all thermostats in the system can be programmed and viewed. The DIGICOM may be applied in stand alone unit control, from 1 to 80 split or packaged systems. When used with a modem, all ZonexCommander software functions can be controlled remotely. The DIGICOM requires 24V AC power from either the zone system or HVAC unit transformer, with the addition of a two conductor, twisted pair cable for communications. Dimensions: 2-7/8" W x 4-1/2" H x 1" D.

**101PROG:** Features a battery powered, 7-day programmable, auto changeover control for single stage heating and cooling applications. Thermostat can be programmed for up to four periods per day, and offers three operating modes: Manual, Automatic and Vacation. Blower operation is manual selectable for auto, on, or programmed for fossil fuel or electric heat, fan cycling. The oversized LCD display clearly shows the time, day of the week, space temperature, and selected operating mode. The 101PROG also provides for mode control through an optional telephone controller. Dimensions are 3.75"W x 5"H x 1"D. Color: White.



### ZONE THERMOSTATS – COMPATIBILITY

The 101ASSB gas/electric and 101AACBHP heat pump controllers are compatible with most thermostats, offering a wide thermostat selection to the installing contractor. NOTE: the 101AACBHP pump controller utilizes gas/electric thermostats. When using other than Zonex Systems thermostats, please refer to the following guidelines:

**Electronic Thermostats:** Digital thermostats requiring 24V AC power must be "Hard wired" with a separate R and C or common terminal. Power robbing type thermostats are not compatible. All types of battery operated thermostats may be used with any System 2000 control system.

**Mechanical Thermostats:** When using a mechanical thermostat, ensure the cooling compensator (anticipator) is removed, and the heating anticipator is shorted or set to its lowest setting.

Please contact Factory Technical Support for additional thermostat compatibility information.

## ZONE THERMOSTATS – REMOTE SENSORS

The Zonex Systems digital thermostats can be ordered with a remote sensor. Remote sensors are useful if you would like to place the thermostat and sensor in different locations. Simply add "RS" at the end of the part number to order with a remote sensor; i.e.: "101DIGIRS".

**Wiring:** The remote sensor must be wired with a minimum 18 ga., two conductor shielded cable, with a maximum length of 200 feet. The wires have no polarity. Use field supplied wire nuts to connect the sensor. Flare back and tape off the cable shield closest to the sensor. Connect the shield at the thermostat to the "R" terminal.

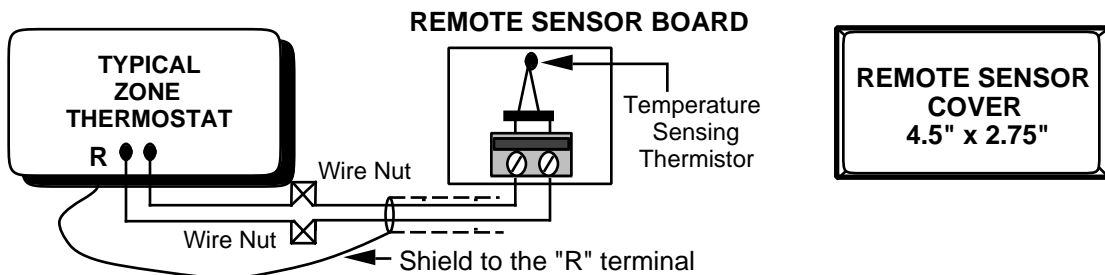

# ZONE DAMPERS

*Zonex Systems* zone dampers are used in cooling/heating systems to provide room by room zone control. The damper is provided with a factory mounted relay board and zone actuator. Each zone damper is

controlled by a zone thermostat. More than one damper can be controlled by one zone thermostat; see Slaving Dampers. Use the table below to determine which zone dampers to use.

SYSTEM SIZE	MAXIMUM DIFFERENTIAL PRESSURE	ROUND DAMPER	RECTANGULAR DAMPER
5 TONS OR UNDER	0.5"	LOW PRESSURE	LOW PRESSURE
UNDER 7.5 TONS	1"	MEDIUM PRESSURE	MEDIUM PRESSURE
7.5 TONS OF LARGER	1.75"	MEDIUM PRESSURE	HEAVY DUTY

Maximum Differential Pressure refers to the maximum static pressure drop in inches of water column between the input (upstream) of the zone damper and the output (downstream) when the damper is closed.

## ROUND ZONE DAMPERS

There are two styles of round zone dampers, low pressure or medium pressure. For systems 5 tons or under with a maximum differential static

pressure of 0.5", use low pressure dampers. Otherwise use medium pressure for up to 1.75" differential pressure on any system over 5 tons.

### ROUND LOW PRESSURE ZONE DAMPERS

*Zonex Systems* round low pressure zone dampers can be used for systems up to 5 tons with a maximum differential static pressure of 0.5". These are two position, spring open, power close dampers for very simple operation. Round damper sizes 9 inches and under are manufactured from 24 gauge galvanized steel. Sizes 10", 12", 14" and 16" are made from 20 - 22 gauge steel. All sizes are designed with rolled-in stiffening beads for superior rigidity. The damper pipe is furnished with one crimped end and one straight end for easy installation. A hat section supports a synchronous 24V AC 60Hz 12VA motor and terminal board. The motor is designed for continuous full stall operation. Special winding and heavy duty gearing provide for long motor life and easy spring open operation. A cross pin on the motor shaft provides positive direct drive to the damper blade shaft without a coupling or set screws, allowing for a quick and easy motor change if required. Motor drive time from full open to full close is 30 seconds. Since this is a spring open damper, in the event of power failure, the damper fails to the full open position.



**LOW PRESSURE (101ARZD)**

### ROUND MEDIUM PRESSURE ZONE DAMPERS

*Zonex Systems* round medium pressure zone dampers are recommended for systems over 5 tons or with a maximum differential static pressure up to 1.75". This power open / power close damper is manufactured from 20-22 gauge galvanized steel with rolled-in stiffening beads for superior rigidity. Mechanical minimum and maximum set stops are provided and easily adjustable. The damper pipe is furnished with one crimped end and one straight end for easy installation. A hat section supports a 35 lb./in. 24V, 6 VA power open, power closed actuator with a damper relay board interface. The actuator is designed for full stall operation, with a magnetic clutch to protect the internal gearing. The actuator is direct coupled to the damper shaft, which provides positive operation and offers replacement ease if required. Drive time from full open to full closed is 60 seconds.



**MEDIUM PRESSURE (101AMPD)**

# ZONE DAMPERS

## ROUND LOW & MEDIUM PRESSURE DAMPER SIZES

### ROUND LOW PRESSURE DAMPER

PART #	SIZE	DIAMETER (D)	LENGTH (L)	WIDTH (W)
101ARZD06	6"	6"	10"	9"
101ARZD07	7"	7"	10"	10"
101ARZD08	8"	8"	10"	11"
101ARZD09	9"	9"	11"	12"
101ARZD10	10"	10"	12"	13"
101ARZD12	12"	12"	14"	15"
101ARZD14	14"	14"	16"	17"
101ARZD16	16"	16"	18"	18 1/2"

### ROUND MEDIUM PRESSURE DAMPER

PART #	SIZE	DIAMETER (D)	LENGTH (L)	WIDTH (W)
101AMPD06	6"	6"	10"	9"
101AMPD08	8"	8"	10"	11"
101AMPD10	10"	10"	12"	13"
101AMPD12	12"	12"	14"	15"
101AMPD14	14"	14"	16"	17"
101AMPD16	16"	16"	18"	19"
101AMPD18	18"	18"	23 1/2"	21"

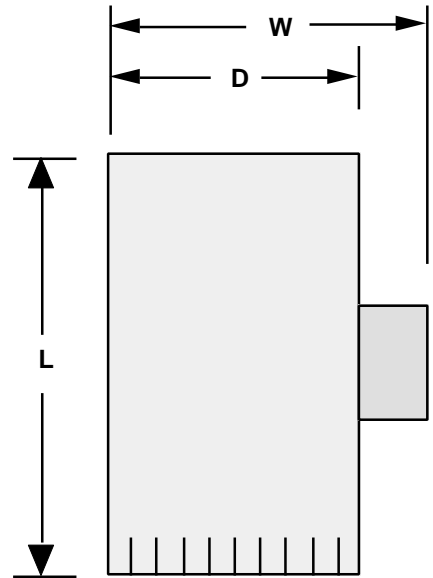

## TYPICAL ROUND CAPACITIES\*

Duct Diameter	Nominal CFM	Duct Velocity FPM	Damper $\Delta P$ " WC
6"	110	540	.014
7"	160	600	.014
8"	250	700	.015
9"	320	725	.015
10"	410	750	.015
12"	660	850	.022
14"	1000	925	.035
16"	1450	1070	.036
18"	2000	1100	.036

\* These air quantities were derived from a duct sizing chart .1" friction loss per 100' of duct. All CFMs listed are approximate. For accurate selection use duct sizing table or device.

# ZONE DAMPERS

## RECTANGULAR ZONE DAMPERS

The rectangular zone dampers come in either low pressure, medium pressure, or heavy duty. For systems 5 tons or under use low pressure. For systems under 10 tons use medium pressure dampers. For systems 10 tons or over use heavy duty dampers. Motor drive time open and close is 90 seconds, except for the low pressure damper which springs open.

### RECTANGULAR LOW PRESSURE ZONE DAMPERS

#### (101EC W x H)

*Zonex Systems* rectangular low pressure dampers can be used for systems up to 5 tons with a maximum differential static pressure of 0.5". These are two position, spring open, power close dampers. They are constructed from heavy duty galvanized steel. The damper is a single blade type that slips into a 2-1/2" wide cutout in the existing duct and attaches with screws via a duct mounting plate. The duct mounting plate is 5" wide. The drive assembly supports a synchronous 24V AC 60Hz 12VA motor and terminal board. The motor is designed for continuous full stall operation. Special winding and heavy duty gearing provide for long motor life and easy spring open operation. A cross pin on the motor shaft provides positive direct drive to the damper shaft without a coupling or set screws. Motor drive time from full open to full close is 30 seconds. Since this is a spring open damper, in the event of power failure the damper fails to the full open position.



LOW PRESSURE (101EC W x H) RECTANGULAR DAMPER

### RECTANGULAR MEDIUM PRESSURE ZONE DAMPERS (101MRTD W x H)

*Zonex Systems* rectangular medium pressure dampers are recommended for systems under 7.5 tons with a maximum differential static pressure of 1". These are power open, power close dampers. They are constructed from heavy duty aluminum and stainless steel. The damper is an opposed blade type that slips into a 3-1/4" wide cutout in the existing duct and attaches with screws via a duct mounting plate. The duct mounting plate is 5" wide. The damper supports a 35 lb./in. 24V, 6 VA power open, power closed actuator with a damper relay board interface. The actuator is designed for full stall operation, with a magnetic clutch to protect the internal gearing. The actuator is direct coupled to the damper shaft, which provides positive operation and offers replacement ease if required.

### RECTANGULAR HEAVY DUTY ZONE DAMPERS

#### (101CD W x H)

*Zonex Systems* rectangular heavy duty dampers are recommended for systems 7.5 tons or larger with a maximum differential static pressure of 1.75". These are power open, power close dampers made of 20 gauge "snap-lock" steel frame with S and Drive duct connections. Allow a 16" gap in the duct for the damper. Formed steel blade stops incorporate a gasket for quiet operation and improved structural rigidity. Rectangular dampers under 10" in height incorporate a single blade design. Dampers 10" or over use opposed blade design. A full stall motor, drawing 6 VA and a relay board control the damper position.



MEDIUM PRESSURE (101MRTD) AND HEAVY DUTY (101CD) RECTANGULAR DAMPERS

# ZONE DAMPERS

## LOW AND MEDIUM PRESSURE RECTANGULAR DAMPER DIMENSIONS

Part Number 101MRTD W x H  
 Sizes available from 8" x 6" up to 24" x 20"

Part Number 101EC W x H  
 Sizes available from 8" x 8" up to 24" x 12"

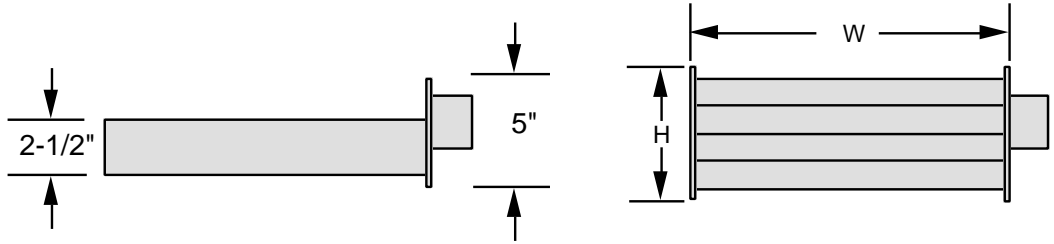

## HEAVY DUTY RECTANGULAR DAMPER DIMENSIONS

Part Number 101CD W x H  
 Sizes available from 8" x 8" up to 48" x 48"

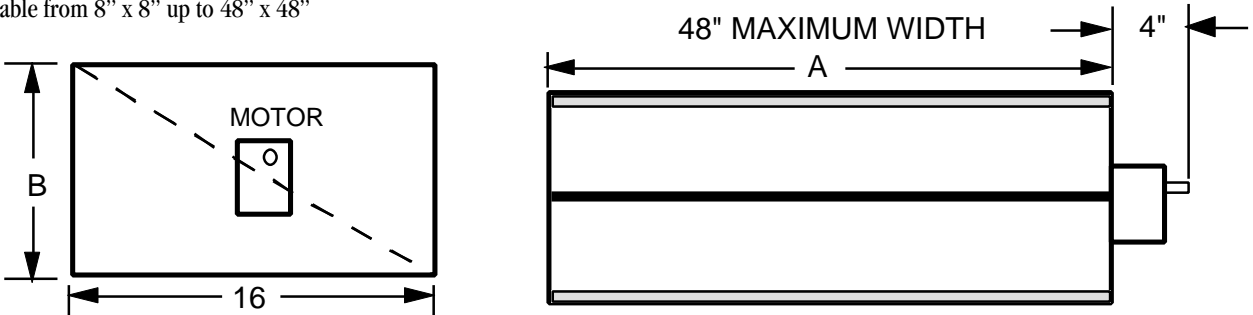

WIDTH	HEIGHT	DEPTH
A	B	16"

Rectangular dampers should operate at 1500 FPM.  
 E.G. A 24" x 12" damper = 2 square feet.  
 2 square feet X 1500FPM = 3000 CFM.

## RECTANGULAR DAMPER CAPACITIES\*

Dampers listed below are standard sizes. For larger sizes and capacities, contact the factory.

		← WIDTH IN INCHES →								
		8	10	12	14	16	18	20	22	24
HEIGHT IN INCHES	6	200	250	310	390	440	500	570	630	700
	8	280	390	490	590	680	770	900	960	1090
	10	390	510	650	800	950	1100	1220	1400	1500
	12	490	650	850	1000	1200	1400	1600	1850	2000
	14			1000	1250	1500	1750	2000	2250	2500
	16			1200	1500	1800	2100	2450	2300	3000
	18			1400	1750	2100	2500	2850	3080	3600
	20									4000

Motors on low and medium pressure dampers will be mounted on the Height (H) side. **Bottom mount motors will be located on the Width (W) side.**  
 \*These air quantities were derived from a duct sizing chart .1" friction loss per 100' of duct. All CFMs listed are approximate. For accurate selection use duct sizing table or device.

# ZONE DAMPERS

## SIZING ZONE DAMPERS

If the ductwork already exists, simply size the damper to fit the ductwork.  
For new systems or retrofit jobs:

- a) Determine CFM from heat gain or loss calculations.
- b) Select damper size by using a duct sizing table or calculator.
- c) Select a *Zonex Systems* damper to fit the duct size selected for that zone.

## WIRING ZONE DAMPERS

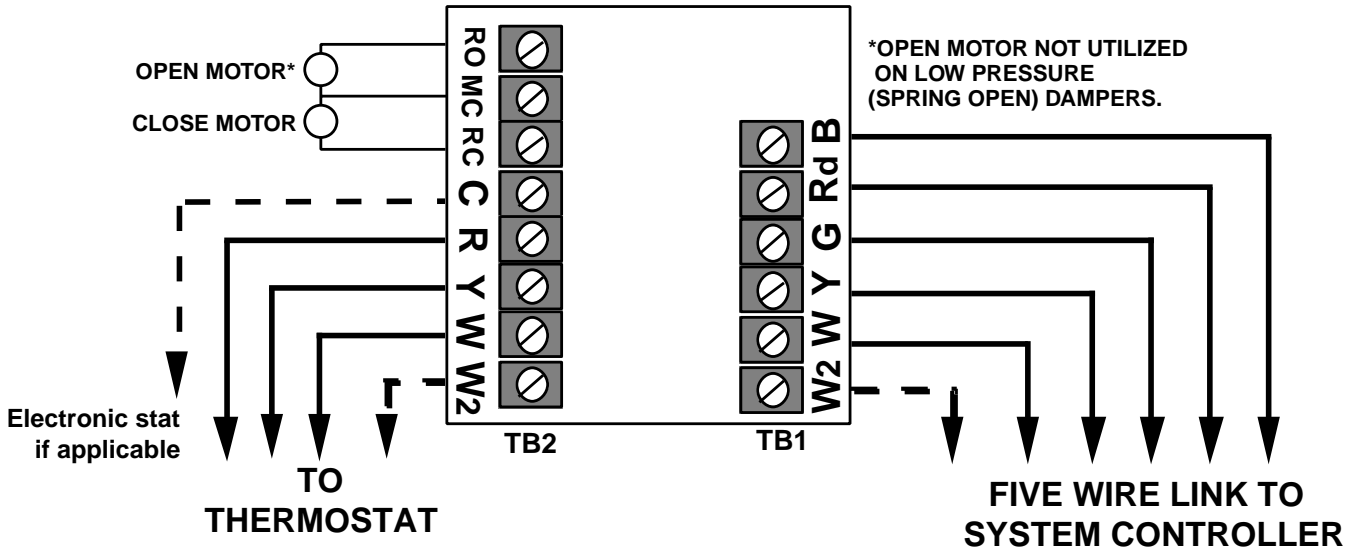

**For heavy-duty rectangular dampers:**  
 CW = RC (Run Closed)  
 COM = MC (Motor Common)  
 CCW = RO (Run Open)

**For heavy-duty round dampers:**  
 CCW = RC (Run Closed)  
 COM = MC (Motor Common)  
 CW = RO (Run Open)

## DAMPER INSTALLATION NOTES

1. Do not exceed 700 FPM in a register/diffuser branch duct.
2. If a damper is installed within 3 feet of register/diffuser, install sound attenuating flex duct between damper and outlet.
3. Zone dampers should be preceded by 2'-4' of straight pipe where possible.
4. In attic installations and high humidity areas, the *Zonex Systems* damper should be insulated along with the ductwork. The hat section on the damper is delivered with insulation between the hat section and pipe. Therefore, insulation should be applied to the round pipe and be butted against the hat section, (do not insulate the motor or relay board). Both motor and the relay board generate enough heat so no condensation will develop on the hat section.
5. Remember to allow a 16" gap in the duct for Heavy Duty rectangular dampers.
6. Low and Medium pressure rectangular dampers slide into a 3-1/4" wide cutout in the side of the preexisting ductwork.



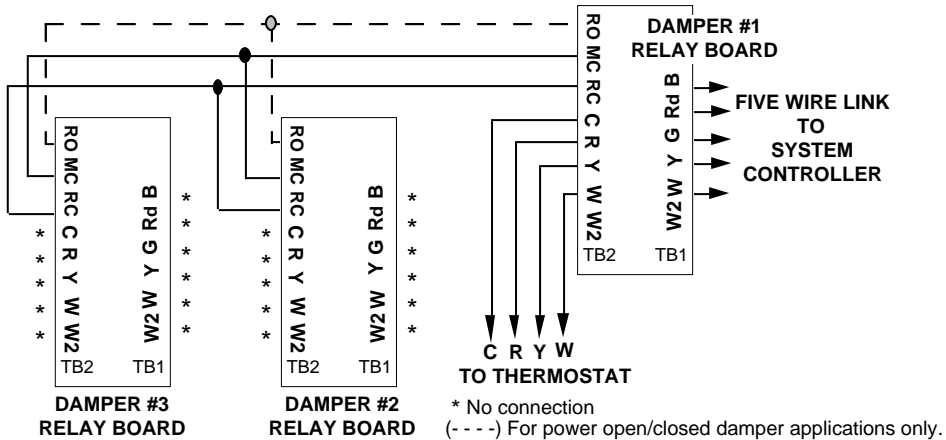

# BYPASS DAMPERS – BAROMETRIC

## INSTALLATION

The round barometric bypass damper can be installed in any position. This damper is factory set for horizontal installation and can be field modified for vertical installation. Do not run speed screws into damper housing. Screws may interfere with damper travel. Make sure counter weight is not obstructed in any way.

- Install the bypass damper between the supply and return plenums of the unit. It must be the first tap off the supply plenum.
- Be sure the air flows through the damper in the proper direction as indicated by the arrow on the damper. Airflow is always from supply to return plenum. Be certain the damper shaft is horizontal.
- Loosen counter weight with allen wrench.
- Loosen lever arm from damper shaft and allow to hang straight down.
- Fully close damper by grabbing damper shaft on side attached to lever arm and turning clockwise until it stops.
- While holding the damper fully closed, rotate the lever arm a little to the right (facing the damper) and then screw in to tighten to the damper shaft. Then tighten lock nut.
- Be sure the damper is being held closed by the counter weight. Proceed to set up.

## BAROMETRIC BYPASS SETUP

- Turn off all thermostats.
- Turn on Switching Center/Controller and set fan switch to “ON” position. Allow fan to run for 5 minutes to equalize pressure. Then make sure all dampers are open by checking for air flow out of each damper.
- By moving counter weight up or down the lever arm, adjust it so that the damper just wants to start opening.
- If the damper cannot be held closed with the counter weight all the way at the bottom of the lever arm, then hold the damper shaft, loosen the lever arm from the damper shaft, and rotate the lever arm further to the right and retighten. Repeat Step C.
- The barometric bypass damper is now calibrated.

## BAROMETRIC BYPASS STARTUP TEST

- Have at least half of the zones call for either heating or cooling.
- Check to be sure the calling zone dampers are open, (air is flowing).
- Verify the bypass damper is open. Note, the damper may not fully open.
- If the open zones are not noisy, the bypass damper is set.

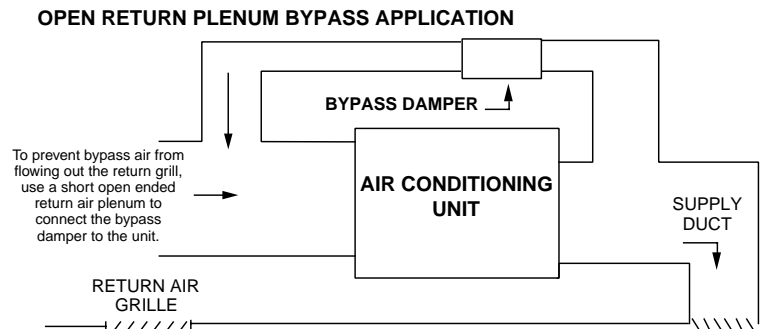
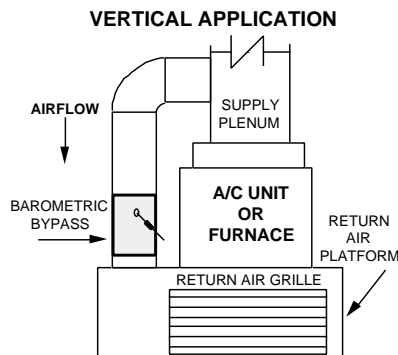
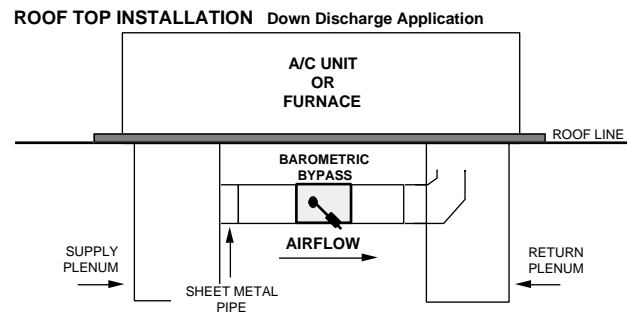
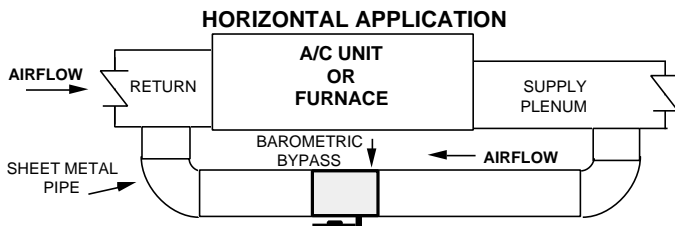

# BYPASS DAMPERS – ELECTRONIC

## ELECTRONIC BYPASS DAMPERS

Bypass dampers are used to provide constant air delivery through the air handling unit. This is done by bypassing excess air from the supply duct back to the return duct. As a zone is satisfied its zone damper closes. When this happens, the bypass damper opens just enough to bypass the excess air. This will control static pressure and noise at the diffusers.

The Electronic Bypass Damper can be used on any size system over. The damper can be round or rectangular and multiple dampers can be slaved together. The Electronic Bypass Damper consists of a medium pressure round or a heavy duty rectangular damper and a static pressure sensor.

## SIZING ELECTRONIC BYPASS DAMPERS

When only the smallest zone is calling, the maximum amount of excess supply air will flow through the bypass damper.

## CFM CALCULATION

To determine the proper size bypass damper:

- Calculate total air volume at 400 CFM per Ton.
- Calculate air volume of smallest zone in CFM .
- Calculate bypass CFM by subtracting the smallest zone air volume from the total.  
(A - B = C).

## ROUND BYPASS DAMPER SELECTION

When you know the bypass CFM requirement as determined in the “CFM calculation” section, use the ROUND BYPASS SELECTION TABLE. From the table, select the bypass damper with the CFM rating equal to or greater than the value calculated in step C of CFM Calculation.

**Example:** We know the smallest zone air volume is 400 CFM and we have a four ton system. Thus the air volume we need to bypass is  $(400 * 4) - 400$  which equals 1200 CFM. Using the ROUND BYPASS SELECTION TABLE, we would select a 12 inch bypass since it can handle up to 1250 CFM of air.

Never exceed 16 inches for the round bypass damper. If you need to bypass more than 2200 CFM, either use a rectangular bypass or slave multiple round bypass dampers.

## RECTANGULAR BYPASS DAMPER SELECTION

When you know the bypass CFM requirement as determined in the “CFM calculation” section, use the RECTANGULAR BYPASS SELECTION TABLE. From the table, select the bypass damper with the CFM rating equal to or greater than the value calculated in step C of CFM Calculation.

**Example:** We know the smallest zone air volume is 250 CFM and we have a 7-1/2 ton system. Thus the air volume we need to bypass is  $(400 * 7.5) - 250$  which equals 2750 CFM. Using the RECTANGULAR BYPASS SELECTION TABLE, we see the smallest damper we can use is a 12” x 22” or a 22” x 12”.



RECTANGULAR & ROUND BYPASS DAMPER WITH THE STATIC PRESSURE CONTROL

ROUND BYPASS SELECTION TABLE

Diameter	CFM
6"	320
8"	560
10"	900
12"	1250
14"	1700
16"	2200

ROUND DIMENSIONAL DATA

PART #	SIZE	D	L	W
STMPD06	6	6"	10"	9"
STMPD08	8	8"	10"	11"
STMPD10	10	10"	12"	13"
STMPD12	12	12"	14"	15"
STMPD14	14	14"	16"	17"
STMPD16	16	16"	18"	19"

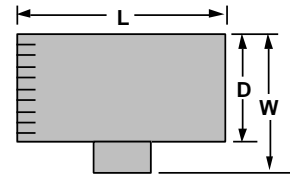

## RECTANGULAR BYPASS DAMPERS

SELECT FROM 8 X 8 THRU 48 X 48

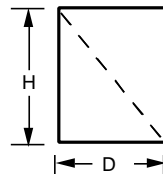

WIDTH	HEIGHT	DEPTH
W	H	16"

Part Number STCD W X H

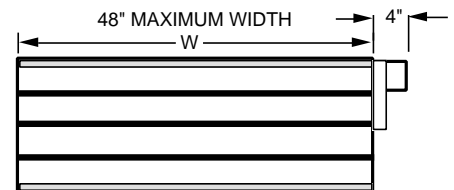

Rectangular bypass dampers should operate at 1500 FPM\*  
E.G. A 24" x 12" damper = 2 square feet.  
2 square feet X 1500FPM = 3000 CFM.

\* FPM = Feet Per Minute

# BYPASS DAMPERS – ELECTRONIC

## RECTANGULAR BYPASS SELECTION TABLE

		WIDTH IN INCHES														
		8	10	12	14	16	18	20	22	24	28	32	36	40	44	48
HEIGHT IN INCHES	8	667	833	1000	1167	1333	1500	1667	1833	2000	2333	2667	3000	3333	3667	4000
	10	833	1042	1250	1458	1667	1875	2083	2292	2500	2917	3333	3750	4167	4583	5000
	12	1000	1250	1500	1750	2000	2250	2500	2750	3000	3500	4000	4500	5000	5500	6000
	14	1167	1458	1750	2042	2333	2625	2917	3208	3500	4083	4667	5250	5833	6417	7000
	16	1333	1667	2000	2333	2667	3000	3333	3667	4000	4667	5333	6000	6667	7333	8000
	18	1500	1875	2250	2625	3000	3375	3750	4125	4500	5250	6000	6750	7500	8250	9000
	20	1667	2083	2500	2917	3333	3750	4167	4583	5000	5833	6667	7500	8333	9167	10000
	22	1833	2292	2750	3208	3667	4125	4583	5042	5500	6417	7333	8250	9167	10083	11000
	24	2000	2500	3000	3500	4000	4500	5000	5500	6000	7000	8000	9000	10000	11000	12000
	28	2333	2917	3500	4083	4667	5250	5833	6417	7000	8167	9333	10500	11667	12833	14000
	32	2667	3333	4000	4667	5333	6000	6667	7333	8000	9333	10667	12000	13333	14667	16000
	36	3000	3750	4500	5250	6000	6750	7500	8250	9000	10500	12000	13500	15000	16500	18000
	40	3333	4167	5000	5833	6667	7500	8333	9167	10000	11667	13333	15000	16667	18333	20000
	44	3667	4583	5500	6417	7333	8250	9167	10083	11000	12833	14667	16500	18333	20167	22000
48	4000	5000	6000	7000	8000	9000	10000	11000	12000	14000	16000	18000	20000	22000	24000	

Bypass air in CFM. Calculated at 1500 FPM.

Formula used:  $B = W \times H / 144 \times 1500$ , where B = Bypass air in CFM, W = damper width in inches, H = damper height in inches, 144 = 144 sq. inches per sq. ft., 1500 = 1500 FPM.

## BYPASS POSITION INDICATOR

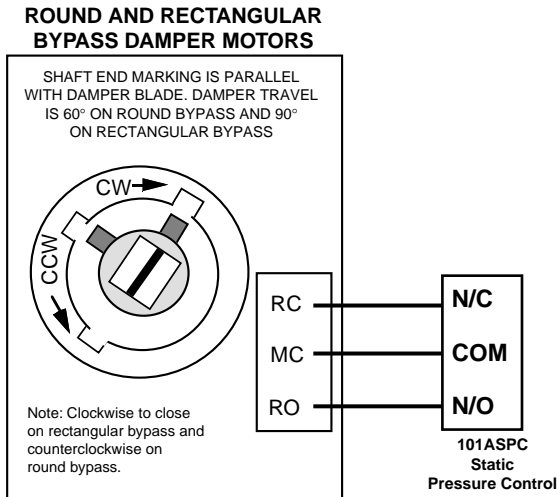

## SLAVING BYPASS DAMPERS

Use only one Pressure Sensor when slaving two or more Bypass Dampers together. Connect the Pressure Sensor to one damper as described above. Connect the slave dampers in parallel as shown. Up to 4 dampers can be slaved to one Sensor. The slaved dampers will self synchronize each time the dampers reach full open or full close.

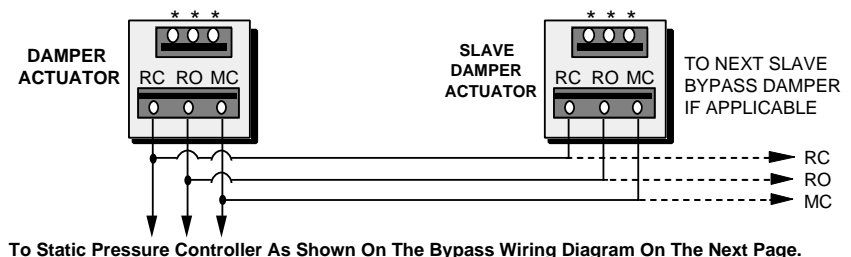

# BYPASS DAMPER – STATIC PRESSURE CONTROLLER

The Static Pressure Controller controls a standard medium pressure round damper (STMPD) or the heavy duty rectangular damper (STCD) by maintaining constant static pressure in the duct downstream of the bypass takeoff. As the zone dampers close, the static pressure increases. When this happens, the static pressure controller opens the bypass damper to bring the static pressure back to the setpoint.

## STATIC PRESSURE CONTROLLER DESCRIPTION

- A: Mounting tabs.
- B: Supply air barb.
- C: Reference air, "LOW", barb.
- D: Diaphragm must be mounted vertically.
- E: Pressure adjusting screw.
- F: Normally closed, N/C, terminal.
- G: Normally open, N/O, terminal.
- H: Common, COM, terminal.

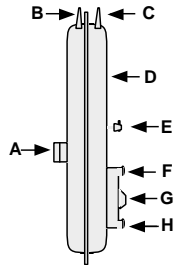

## STATIC PRESSURE CONTROLLER INSTALLATION

- a. Select location for pressure sensor tube. Location should be in supply duct, downstream of bypass takeoff, upstream of any zone dampers and perpendicular to the air flow.
- b. Drill 5/16" hole at selected location for pressure sensor tube.
- c. Mount Static Pressure Controller near the drilled hole with the diaphragm of the sensor vertical. The controller must be mounted on a stable, non vibrating surface.
- d. Attach 5/16" pressure sensor tube, supplied, to the barb of the Static Pressure Controller located closest to the mounting tabs. The other barb, labeled "LOW", is left open if the Controller is in the conditioned building. If the Controller is located outside the building, another tube, not provided, must be connected between the "LOW" barb and a location inside the building.
- e. Remove the terminal cover and wire as shown in the wiring diagram.
- f. Reattach terminal cover. Installation is complete. Proceed to Static Pressure Controller Setup.

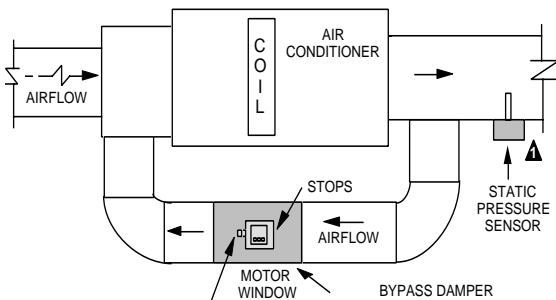

▲ Insert the tube into the side of the duct, approximately 3". Make sure the tube is perpendicular to the air flow.

## STATIC PRESSURE CONTROLLER SETUP

**Note:** 24V ac may be read on both terminals (RO & RC to MC) due to voltage bleeding thru the motor windings. Disconnect the RO or RC wire to determine which wire is energizing the motor.

- a. Ensure all dampers are open and blower is running on high speed.

Zonex Systems recommends de-energizing the bypass damper when the blower fan turns off. If not installed as recommended, when the blower fan turns off the bypass will fully close. Then when the blower fan turns back on, there could be excessive air supplied to the calling zone, causing excessive air noise until the bypass is able to open sufficiently. An alternative wiring diagram is provided using an additional static pressure sensor to deenergize the bypass damper.

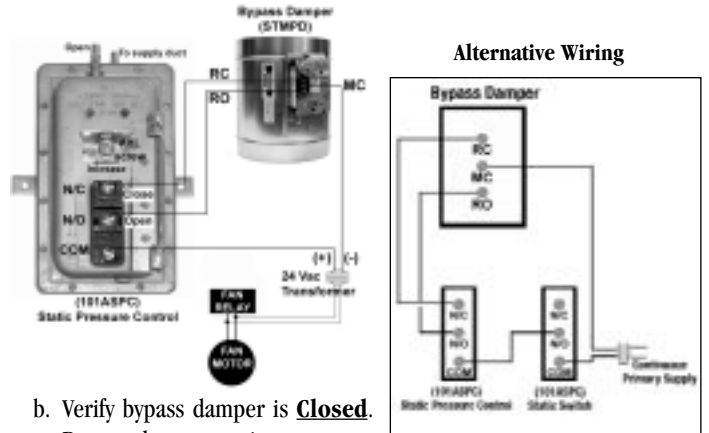

- b. Verify bypass damper is **Closed**. Bypass dampers using a square motor have a grey release lever on the bottom/side of the damper (near motor) to manually open or close the damper.
- c. At 101ASPC Static Pressure Controller, remove the **NO** wire from the micro switch. Connect A/C voltmeter (or test light) to **COM** and **NC** terminals of static pressure controller. **Zero V ac** (no light) should be present, ensuring a connection is made between **COM** and **NC**. If 24V ac is present (light on), turn adjustment screw on 101ASPC Static Pressure Controller clockwise (**CW**) until connection is made and 0V ac (no light) is obtained. Do Not Overtighten Adjusting Screw.
- d. Verify bypass damper is **Closed**. Slowly back out adjusting screw (**CCW**) until 24V ac (light on) is present ensuring no connection between **COM** and **NC**. **STOP**. Slowly turn adjusting screw in (**CW**) until 0V ac (no light) is present. **STOP**. Bypass damper should be on verge of opening but still closed with all zone dampers open and the blower fan on high speed.
- e. If the bypass damper sizing and duct design are correct, this completes the bypass damper setup. Connect all wires and proceed to Bypass Checkout.

## BYPASS CHECKOUT FOR STATIC PRESSURE CONTROLLER

- a. Make a cool call at the zone thermostat of the smallest (damper size) zone.
- b. Verify all zone dampers are closed except for calling zone.
- c. Verify noise at zone register is not excessive. Adjust static pressure controller **CCW** to lower noise (airflow) or **CW** to increase airflow until too noisy.

# CAPACITY CONTROLLERS

An HVAC system is sized to handle the load of an entire home or building. Because of this, when all the zones are not calling, the load to the HVAC system can diminish below its designed capacity. Left unchecked, the A/C coil could freeze up causing compressor slugging or the furnace could overheat causing premature heat exchanger failure. To compensate for this, a Capacity Controller is needed.

The basic function of the Capacity Controller is to monitor the leaving air temperature and cycle the unit on and off to maintain a leaving air temperature within set parameters. Zonex Systems offers six unique capacity controllers to meet all your application needs: TRLAT, 101CAPGE, CAPL-2, CAPL-4, SYCAP and TRFPC.

## CAPACITY CONTROLLER SELECTION

Select the Capacity Controller best suited for your application based on the following table and feature list.

P/N	GE/HP	# STAGES	ECONO CNTRL	CUT-IN	SET-POINT	LEAVING AIR	COMPRESSOR MIN. RUN	FAN CONTROL
101CAPGE	GE	1 HT, 1 CL	NO	NO	FULL RANGE	YES	NO	NO
TRLAT	GE	1 HT, 1 CL	NO	NO	4 HT, 4 CL	NO	NO	YES
CAPL-2	GE	2 HT, 2 CL	YES	YES	FULL RANGE	YES	YES	YES
CAPL-4	GE	4 HT, 4 CL	YES	YES	FULL RANGE	YES	YES	YES
SYCAP	HP	2 HT, 1 CL	NO	NO	FULL RANGE	YES	NO	NO
TRFPC	GE	1 CL	NO	NO	FULL RANGE	NO	NO	NO

## FEATURE LIST

**GE/HP** – Gas/Electric or Heat Pump. For Gas/Electric HVAC systems, select GE. For heat pumps select HP unless heat pump uses GE thermostats (no external reversing valve control), then select GE.

**# STAGES** – Maximum number of HVAC system heat and cool stages.

**ECONO CNTRL** – This feature allows the economizer to operate as an additional stage of cooling when outdoor air conditions are acceptable. May be used with HVAC systems that utilize an economizer.

**CUT-IN** – This advanced feature separates the cut-in setpoint from the cut-out setpoint. This permits better staging and leaving air temperature control. Example: Without this feature, in cool mode with a cut-out setpoint of 48 degrees, the compressor will turn off if the leaving air drops below 48 and, after a time delay, turn back on when the air rises above 48. With this feature, if the cut-out is 48, the cut-in will be 58. If the air drops below 48 the compressor will turn off. It will not turn on, however, until the air temperature rises above 58 and a time delay has elapsed. This gives longer compressor running times and maintains a more comfortable leaving air temperature.

**SETPOINT** – Number of setpoints available for heat and cool.

**LEAVING AIR DISPLAY** – Digitally displays the leaving air temperature. This is useful for troubleshooting and system monitoring.

**COMPRESSOR MIN. RUN** – Runs the compressors a minimum of four minutes whenever they are energized. This ensures proper oil return and increased compressor life.

**FAN CONTROL** – Runs the indoor blower fan during capacity cut-out. This ensures the heat exchanger properly cools down and the AC coil warms up during capacity cut-out. It also provides better zone temperature control by providing conditioned air during capacity cut-out periods. This feature is not provided or necessary for heat pumps because blower fan is continuously energized as long as there is a call. This feature is also not necessary if blower fan is run continuously.

# CAPACITY CONTROLLERS – 101CAPGE

## OVERVIEW

The 101CAPGE is a Gas/Electric Capacity Controller that digitally displays leaving air temperature. It should be utilized for single stage applications. For multistage HVAC systems, use either the CAPL-2 or CAPL-4 Capacity Controller.

The Zonex Systems 101CAPGE capacity controller protects both the air conditioner and furnace. It simply measures the leaving air temperature. If the air gets too cold (drops below the cool cutout setpoint), it breaks the “Y” connection, disengaging the compressor. If the air gets too warm (rises above the heat cutout setpoint), it breaks the “W” connection, de-energizing the furnace. To prevent short cycling, the compressor or furnace cannot reenergize for at least four minutes after cutout. The heating and cooling cutout setpoints can be changed by the installer.

The 101CAPGE has a three digit LED display and two push buttons. Normally the leaving air temperature is displayed. When the push buttons are pressed the cut-out setpoints are displayed.

## OPERATION

The 101CAPGE has three modes of operation: in range, out of range and enable mode.

**In Range** – If the leaving air temperature is between the cool and heat cutout setpoints and the 101CAPGE is not in cutout time delay, light DL1

is off and relay K1 is made, permitting the System Controller to energize the compressor or furnace. The leaving air temperature is displayed on the digital display during this time.

**Out of Range** – If the leaving air temperature drops below the cool cutout setpoint or rises above the heat cutout setpoint, light DL1 is lit and the relay contacts between Y1 Y1 and W1 W1 break, de-energizing the compressor or furnace. Four minutes after the leaving air temperature has returned within operating range light DL1 is turned off and the relay contacts close, making Y1 Y1 and W1 W1 and energizing the furnace or compressor. The leaving air temperature is displayed on the digital display during this time.

**Enable Mode** – On the digital display, “E” followed by the leaving air temperature indicates that the 101CAPGE is in the Enable Mode. The purpose of this mode is to ensure the furnace can turn on in a cold building and the air conditioner can turn on in a hot building. Enable Mode is entered if the leaving air temperature is below the cool cutout setpoint or above the heat cutout setpoint for more than eight minutes. The relay contacts are made during this mode, enabling the furnace or air conditioner to run. After the leaving air temperature has returned within operating range the 101CAPGE will return to normal operation, displaying only the leaving air temperature.

## COMPONENTS

The 101CAPGE consists of the following:

- A. **Digital Display** – Three digit LED. Normally displays the leaving air temperature of the HVAC unit. When “E” is displayed, it indicates 101CAPGE is in Enable mode; refer to OPERATION section. When the UP/DN buttons are pressed, the cutout setpoints are displayed. Refer to the Setpoint Calibration section for reading and adjusting the setpoints.
- B. **Microcontroller** – Activates and controls outputs based upon leaving air temperature comparison with programmed setpoints. Occasionally software upgrades may become available. If so, the 101CAPGE software can be field upgraded by changing this microcontroller.
- C. **Cut-out Indicator Lights** – DL1 light is on when relay K1 is energized. See E.
- D. **Thermometer Calibrator** – Calibrates the leaving air temperature thermometer. Turn clockwise to lower temperature. Turn counterclockwise to raise. Refer to CALIBRATION section for complete calibration information.
- E. **Relays K1 and K2** – DPDT, NC relays. When K1 is energized, it breaks contact between Y1 Y1 and W1 W1 terminals.

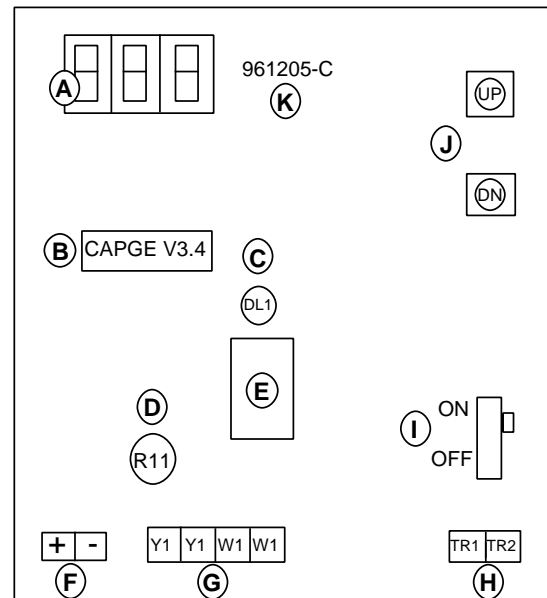

- F. **Leaving Air Sensor (LAS) Terminals** – Leaving air temperature sensor is connected to the 101CAPGE here. Red to + and white to -. The sensor monitors the leaving air of the HVAC system. If preferred, the 101CAPGE can be mounted up to 500 feet from the sensor. See INSTALLATION section for further information.

# CAPACITY CONTROLLERS – 101CAPGE

- G. **HVAC/System Controller Interface Terminals** – Y1 controls the A/C compressor and W1 controls the furnace. W1 controls the first stage furnace and W2 controls second stage. One Y and W connect to the System Controller, the other Y and W connect to the HVAC unit. It does not matter which W/Y connects to the System Controller and which connects to the HVAC unit. See WIRING section for detailed wiring instructions.
- H. **Power Source Terminals** – Connect to 24V AC power source. Recommend using either the HVAC unit transformer or the System Controller transformer. 101CAPGE uses less than 2 VA of power. See WIRING section for detailed wiring instructions.
- I. **Power Switch** – When off, the display is off, the 101CAPGE is disabled and the relay contacts are closed. The HVAC unit can run at this time but will not have capacity control protection. When the switch is on, the display is on and the 101CAPGE is operational.
- J. **Setpoint Adjustment** – Use the UP/DN buttons to view and change the cut-out setpoints. Refer to the Setpoints, Calibration section (Page 41) for reading and adjusting the setpoints.
- K. **Board Number** – This number indicates the circuit board number and revision. You may need to know this number if conferring with technical support.

## 101CAPGE WIRING

The 101CAPGE is installed as detailed in the Capacity Controllers installation section, Page 40. The following wiring diagrams show how to wire the 101CAPGE to the System Controller and the HVAC unit. Terminals TR1 and TR2 of the 101CAPGE can be wired either to R and C of the HVAC Unit or to TR1 and TR2 of the System Controller.

There are two ways of wiring the 101CAPGE: without a fan relay and with a fan relay.

Use the “Without Fan Relay” drawing if the indoor blower fan will be running continuously or the furnace keeps the indoor blower fan on for at least three minutes after the heat call is removed (W de-energized).

Use the “With Fan Relay” drawing if the indoor blower fan will not be running continuously and the furnace does not keep the indoor blower fan on for at least three minutes after the heat call is removed (W de-energized). The relay is a SPDT, 24V AC.

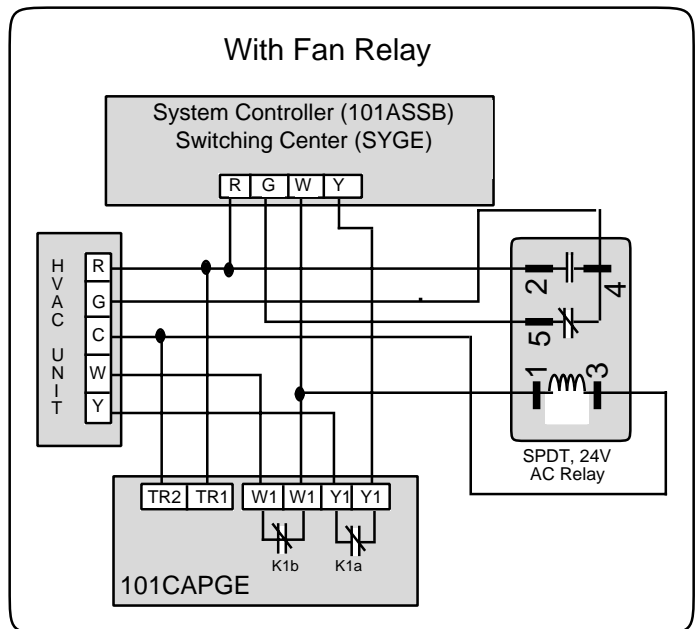
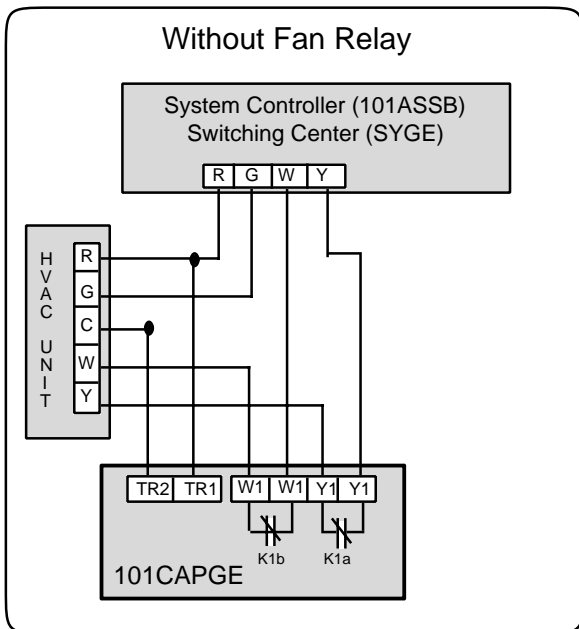



# CAPACITY CONTROLLERS – TRLAT

## OVERVIEW

The Zonex Systems TRLAT is a single stage Gas/Electric or Heat Pump Capacity Controller. However, the heat pump feature is not compatible with the Zonex Systems System 1000/2000 Zoning Systems so we will only address the Gas/Electric features. If you have a heat pump that uses heat pump controls refer to the SYCAP for System 1000 and LAS for System 2000.

The TRLAT Capacity Controller protects both the air conditioner and furnace. It simply measures the leaving air temperature. If the air gets too cold (drops below the cool cutout setpoint), it breaks the “Y” connection, disengaging the compressor. If the air gets too warm (rises above the heat cut-out setpoint), it breaks the “W” connection, de-energizing the furnace. To prevent short cycling, the compressor or furnace cannot reenergize for at least four minutes after cut-out. The heating and cooling cut-out setpoints can be changed by the installer.

## OPERATION

**Cool mode:** If the leaving air temperature drops below the TRLAT cooling setpoint (field settable to 41, 44, 47 or 50 degrees Fahrenheit), the Y (Controller) breaks from Y (Unit) and makes to G. This turns off the compressor and keeps the indoor blower fan running to warm up the evaporator. Four minutes after the leaving air temperature rises above the cooling setpoint, Y (Controller) makes to Y (Unit) and breaks to G. This restarts the compressor and returns indoor blower fan control to the Switching Center/Controller.

**Heat mode:** If the leaving air temperature rises above the TRLAT heating setpoint (field settable to 125, 140, 150 or 160 degrees Fahrenheit), the W (Controller) breaks from W (Unit) and makes to G. This turns off the heater and keeps the indoor blower fan running to cool down the heater. Four minutes after the leaving air temperature drops below the heating setpoint, W (Controller) makes to W (Unit) and breaks to G. This restarts the heater and returns indoor blower fan control to the heater or Switching Center/Controller.

**Cut-out disable:** The cool cutout is disabled in heat mode. The heat cutout is disabled in cool mode. This permits the heat to turn on in a cold building and the air conditioner to turn on in a hot building. For heat pumps, this also prevents the compressor from cycling off when the heat pump is in defrost mode. The O/B (Controller) input tells the TRLAT which mode of operation (heat or cool) is active.

**NOTE: For GE systems, a jumper wire (factory installed) must be connected between O/B (Controller) and W (Controller).**

## COMPONENTS

- A. Status Lights:  
 DELAY (red): On when compressor or furnace is disabled.  
 PWR (yellow): On when TRLAT is powered.
- B. Jumpers:  
 GE/HP: For gas/electric systems, place jumper on GE and center pin. For heat pumps, place jumper on HP and center pin. (Digitract Systems only)  
 O/B: For heat pumps, if reversing valve is energized in cool mode, place jumper on O and center pin. If reversing valve is energized in heat mode, place jumper on B and center pin.
- C. Unit terminal block: Connects to HVAC unit. O/B – Reversing Valve; R – 24V AC hot; G – Blower fan; C – 24V AC rtn; W – heat; Y – compressor. See WIRING section for detailed wiring instructions.
- D. Controller terminal block: Connects to System Controller. Terminal designations same as for Unit terminal block. See WIRING section for detailed wiring instructions.
- E. Leaving Air Sensor (LAS) Terminals: Leaving air temperature sensor is connected to the TRLAT here. Red to + and white to -. The sensor monitors the leaving air of the HVAC system. If preferred, the TRLAT can be mounted up to 500 feet from the sensor. See INSTALLATION section for further information.
- F. Jumper wire: Factory installed. Must be connected between O/B (Controller) and W (Controller) for GE systems and removed for heat pumps.
- G. Setpoint Select: Sets the heat and cool cutoff setpoints. See SETPOINT SETUP, TRLAT section.

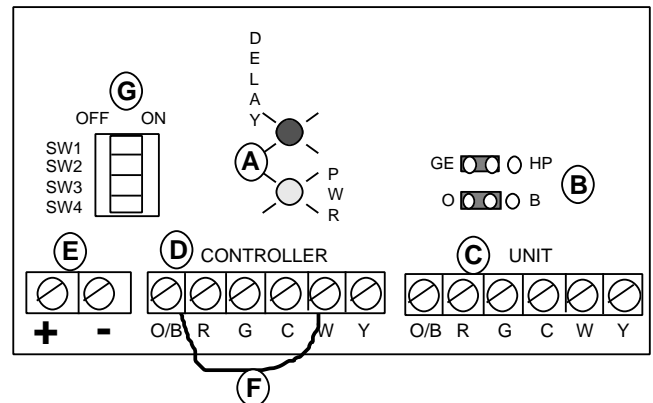

# CAPACITY CONTROLLERS – TRLAT

## SETPOINT SETUP, TRLAT

A four pole dip switch is used to designate the desired heat and cool cutoff setpoints. Using the table to right, set the switch positions to correspond to the cutoff temperatures desired. For heat pumps, the heat cutoff point is 118 degrees and unchangeable.

		Cool Cut-out
SW1	SW2	
On	On	50 Deg F
On	Off	47 Deg F
Off	On	44 Deg F
Off	Off	41 Deg F
		Heat Cut-out
SW3	SW4	
On	On	125 Deg F
On	Off	140 Deg F
Off	On	150 Deg F
Off	Off	160 Deg F

## TRLAT WIRING

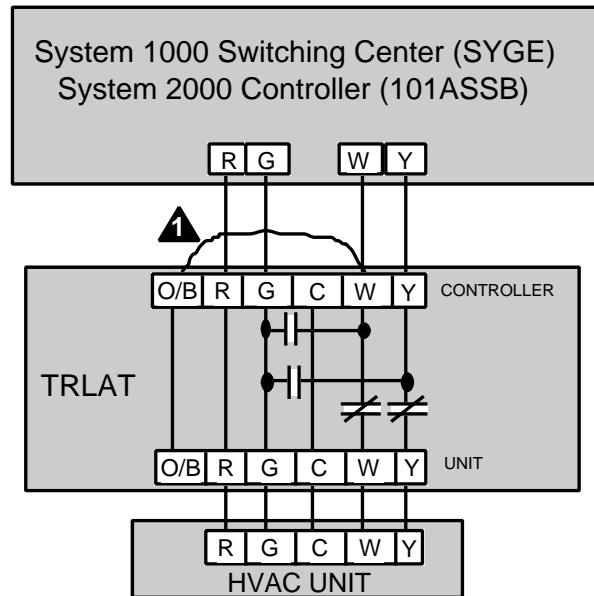

The TRLAT is installed as detailed in the Capacity Controllers Installation section, page 40. Wire as shown above.

### ⚠ WARNING

Jumper wire (factory installed) must be connected for GE applications between W (Controller) and O/B (Controller). If not, the TRLAT will not shut off the heater when the heat setpoint is exceeded.

# CAPACITY CONTROLLERS – TRFPC

## OVERVIEW

The TRFPC is an inexpensive no frills single stage air conditioning only Capacity Controller. It will simply interrupt power to the air conditioning compressor when the supply air temperature drops below 47 degrees Fahrenheit and re-energize when the temperature rises above 47 degrees. This setpoint is non-adjustable. It has no control for preventing compressor short cycling. If your air conditioner does not have a non-recycle timer, we highly recommend adding one when using this Capacity Controller to prevent short cycling.

## OPERATION

The TRFPC will interrupt power to the air conditioning compressor when the supply air temperature drops below 47 degrees Fahrenheit and re-energize when the temperature rises above 47 degrees. This setpoint is non-adjustable. The TRFPC is powered by the “Y” terminal. Thus, the TRFPC will operate only when there is a call for cooling (24V at “Y”). A green status light is provided. When on, the compressor can run (relay closed). When off, the “Y” circuit is broken, disengaging the compressor.

## WIRING

The TRFPC is installed as detailed in the Capacity Controllers installation section, page 40. The following wiring diagrams show how to wire the TRFPC to the System Controller and the HVAC unit. Terminal C of the TRFPC must be wired to the HVAC unit’s transformer common.

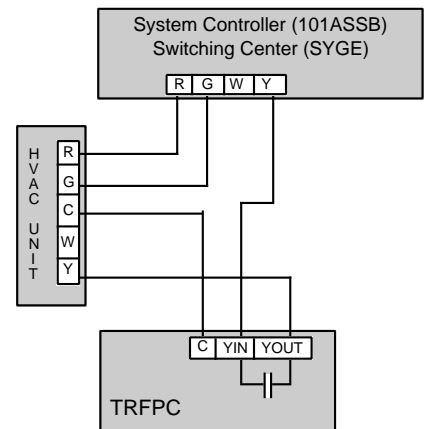

**Note:** A non recycle timer on the air conditioner is strongly recommended to prevent short cycling.

# CAPACITY CONTROLLERS - SYCAP

## OVERVIEW

The SYCAP is a single stage cool, two stage heat Heat Pump Capacity Controller. It works in conjunction with the System 1000 SYHPA Switching Center only. Its function is to control the heat pump coil leaving air temperature within a set operating range.

When the heat pump is running, the SYCAP keeps the heat pump coil leaving air temperature within operating range by turning the heat pump compressor off for a minimum of four minutes if the air temperature gets too cold in cool mode or too hot in heat mode. The SYCAP will also turn on the heat pump auxiliary heat if the coil leaving air temperature is not hot enough in heat mode. The compressor is kept off for a minimum of four minutes to prevent short cycling.

## OPERATION

The SYCAP has two relays (K1 and K2) and two corresponding status lights (DL1- red and DL2- green). Relay K1 is a normally closed relay. When energized, it breaks the connection between Y1 Y1 which disables the heat pump compressor. Relay K2 is a normally open relay. When energized, it makes the connection between W2 W2 which enables the heat pump auxiliary heat.

There are three adjustable setpoints on the SYCAP: Heat Cut-out, Cool Cut-out, and Auxiliary Heat Cut-in. The Heat Cut-out Setpoint is the maximum allowable leaving air temperature in heat mode. If the air temperature rises above this setpoint in heat mode, the compressor is disabled for a minimum of four minutes. The Cool Cut-out setpoint is the minimum allowable leaving air temperature in cool mode. If the air temperature drops below this setpoint in cool mode, the compressor is disabled for a minimum of four minutes. The Auxiliary Heat Cut-in temperature is the minimum allowable leaving air temperature in heat mode. Four minutes after the heat pump compressor has been turned on, if the coil air temperature cannot rise above this setpoint, the auxiliary heat is enabled. The auxiliary heat is disabled when the air temperature rises nine degrees above the Auxiliary Heat Cut-in setpoint.

The SYCAP knows which mode of operation it is in by monitoring the W2 signal from the SYHPA Switching Center. If W2 is energized, it knows the SYHPA is making a heat call.

The following is a detailed operation description of each mode.

**IN RANGE, HEAT MODE** – If the SYHPA Switching Center is making a heat call and the leaving air temperature is below the Heat Cut-out setpoint and above the Auxiliary Heat Cut-in, relays K1 and K2 are de-energized, red light DL1 is off and green light DL2 is off. The leaving air temperature is displayed on the digital display.

**COOL CUT-OUT** – If the SYHPA is making a cool call and the leaving air temperature drops below the Cool-Cut-out setpoint, the connection between Y1 Y1 breaks, red light DL1 turns on, and the Heat Pump compressor is disabled. Every four minutes after Y1 is broken, the leaving air temperature is checked. If the temperature rises above the cool cut-out setpoint, Y1 Y1 is made, red light DL1 turns off and the compressor is re-enabled.

**HEAT CUT-OUT** – If the SYHPA is making a heat call and the leaving air temperature rises above the Heat Cut-out setpoint, the connection between Y2 Y2 breaks, red light DL1 turns on, and the Heat Pump compressor is disabled. Every four minutes after Y2 is broken, the leaving air temperature is checked. If the temperature drops below the heat cut-out setpoint, Y2 Y2 is made, red light DL2 turns off and the compressor is re-enabled.

**AUXILIARY HEAT CONTROL** – Four minutes after the SYHPA initiates a heat call, the leaving air temperature is continuously checked. If the air temperature does not rise above the Auxiliary Heat Cut-in setpoint, green light DL2 turns on, the connection between W2 W2 is made, and the Heat Pump Auxiliary heat is enabled. When the leaving air temperature rises nine degrees above the auxiliary heat cut-in setpoint, green light DL2 turns off, W2 W2 is broken, and the auxiliary heat is disabled.

## SYCAP Components

The SYCAP consist of the following:

- A. Digital Display** – Three digit LED. Normally displays the coil leaving air temperature of the heat pump. When “E” displayed, indicates SYCAP is in Enable mode; refer to OPERATION section. When the UP/DN buttons are pressed, the cutout setpoints are displayed. Refer to the Setpoint Calibration section for reading and adjusting the setpoints.
- B. Microcontroller** – Brains of the SYCAP and where the program resides. Occasionally, software upgrades may become available. If so, the SYCAP software can be field upgraded by changing this micro-controller.
- C. Status Lights** – Red light DL1 is on when relay K1 is energized. Green light DL2 is on when relay K2 is energized. See E.
- D. Thermometer Calibrator** – Calibrates the leaving air temperature thermometer. Turn clockwise to lower temperature. Turn counter-clockwise to raise. Refer to CALIBRATION section for complete calibration information.
- E. Relays K1 and K2** – SPST relays. Relay K1 is a normally closed relay. When energized, it breaks contact between Y1 Y1. Relay K2 is a normally open relay. When energized, makes contact between W2 W2 terminals.
- F. Leaving Air Sensor (LAS) Terminals** – Leaving air temperature sensor is connected to the SYCAP here. Red to + and white to -. The sensor monitors the coil leaving air of the heat pump. If preferred, the SYCAP can be mounted up to 500 feet from the sensor. See INSTALLATION section for further information.
- G. Heat Pump/Switching Center Interface Terminals** – Y1 controls the heat pump compressor. W2 controls the heat pump auxiliary heat. One Y1 and W2 connect to the Switching Center, the other Y1 and W2 connect to the heat pump. It does not matter which W2/Y1 connects to the Switching Center and which connects to the heat pump. See WIRING section for detailed wiring instructions.

# CAPACITY CONTROLLERS - SYCAP

**H. Heat Pump Power Terminals** – Connect to heat pump 24V AC power source. R is 24 V hot. C is 24 V rtn. Cannot be connected to any other power source. SYCAP uses less than 2 VA of power. See WIRING section for detailed wiring instructions.

**I. Power Switch** – When off, the display is off, the SYCAP is disabled and K1 relay contacts are made. The heat pump compressor can run at this time but will not have capacity control protection. The auxiliary heat cannot run. When the switch is on, the display is on and the SYCAP is operational.

**J. Setpoint Adjustment** – Use the UP/DN buttons to view and change the cut-out setpoints. Refer to the Setpoints, Calibration section (Page 41) for reading and adjusting the setpoints.

**K. Board Number** – This number indicates the circuit board number and revision. You may need to know this number if conferring with technical support.

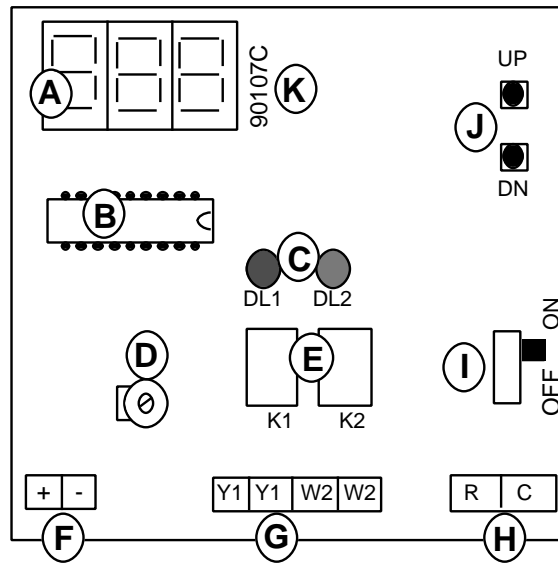

## WIRING

The SYCAP is installed as detailed in the Capacity Controllers Installation section, page 40. Wire as diagrammed below. The W2 terminal from the SYHPA Switching Center must be wired to the SYCAP Capacity Controller even if the Heat Pump does not have auxiliary heat. The SYCAP determines the mode of operation based on this signal.

Terminals R and C of the SYCAP must be wired to terminals R (24V hot) and C (24V rtn) of the Heat Pump system transformer.

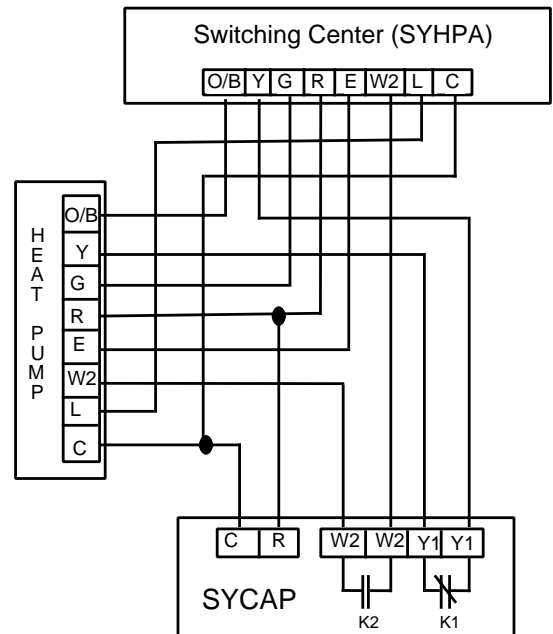

# CAPACITY CONTROLLERS - 101ALAS

## OVERVIEW

The 101ALAS works with the System 2000 Heat Pump System Controller (101AACBHP). The 101ALAS provides leaving air temperature readings to the System Controller, which allows it to make capacity control decisions.

## OPERATION

The 101ACBHP System Controller has four status lights that represent capacity control. The heat Y1 and Y2 red lights indicate heating operation and the cool Y1 and Y2 green lights indicate cooling operation. Heating or cooling will be initiated depending on the position of the reversing valve. When one of the lights turns on, the leaving air temperature in the duct, sensed by the LAS, has exceeded one of the capacity control setpoints. The light will indicate which stage will be turned off. The second stage factory default cut-in temperature for heating is 95 degrees, and for cooling 60 degrees. If the setpoint is exceeded, a stage light will illuminate, the stage will be shut down, and a four-minute time delay will begin. After the four minute delay, if the leaving air temperature has recovered to an acceptable temperature, the stage which was shut down will restart. If the temperature has not recovered, the time delay will continue. If both first and second stage setpoints are exceeded by the leaving air, then a four-minute time delay per stage will go into effect.

## MODIFYING SETPOINT ADJUSTMENT

The Heat Pump Controller is designed so that it is possible to modify the cut-in setpoints for cooling, heating (and electric heat on the Heat Pump Controller). If necessary, locate the potentiometer associated with its test point on the diagram above. "GND" is the common ground test point, TP2

is the cool test point and TP3 is the heat test point. (TP1 is the electric heat test point on the Heat Pump Controller). Clip the leads of a digital volt meter, set to 20 volts DC, between the potentiometer test point that needs to be modified and the ground test point. Rotate the corresponding potentiometer until the meter reads the proper voltage according to Table 2 below.

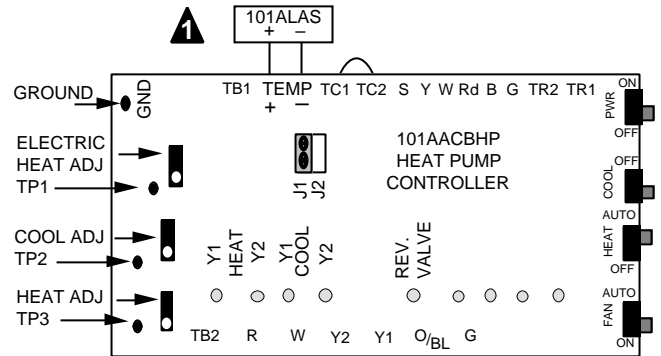

## WIRING

The 101ALAS is installed as detailed in the Capacity Controllers Installation Section, page 40. The + or – terminals of the LAS are wired to the + or – terminal of the 101AACBHP using two conductor 18 gauge thermostat wire.

## LAS VOLTAGE CONVERSION CHARTS

**TABLE 1: CAPACITY CONTROL**

### STAGE CUT-IN TEMPERATURES\*

Cooling			
Second Stage	60	GND & TP2	2.887
Heating			
Second Stage	95	GND & TP3	3.081
Electric Heat	85	GND & TP1	3.025
Discharge Duct Temperature	—	LAS + & –	per table #2

\*The Y2 cut-out temperature is 10° fixed below the cut-in temperature in cooling, and 10° above in heating.

The Y1 cut-out temperature is 15° fixed below the cut-in temperature in cooling, and 25° above in heating.

**TABLE 2: TEMPERATURE TO VOLTAGE CONVERSION CHART**

Deg. F.	DC Volts	Deg. F.	DC Volts	Deg. F.	DC Volts	Deg. F.	DC Volts
40	2.775	70	2.942	100	3.109	130	3.275
41	2.781	71	2.948	101	3.114	131	3.281
42	2.787	72	2.953	102	3.120	132	3.287
43	2.792	73	2.959	103	3.125	133	3.292
44	2.798	74	2.964	104	3.131	134	3.298
45	2.803	75	2.970	105	3.137	135	3.303
46	2.809	76	2.975	106	3.142	136	3.309
47	2.814	77	2.981	107	3.148	137	3.314
48	2.820	78	2.987	108	3.153	138	3.320
49	2.825	79	2.992	109	3.159	139	3.325
50	2.831	80	2.998	110	3.164	140	3.331
51	2.837	81	3.003	111	3.170	141	3.337
52	2.842	82	3.009	112	3.175		
53	2.848	83	3.014	113	3.181		
54	2.853	84	3.020	114	3.187		
55	2.859	85	3.025	115	3.192		
56	2.864	86	3.031	116	3.198		
57	2.870	87	3.037	117	3.203		
58	2.875	88	3.042	118	3.209		
59	2.881	89	3.048	119	3.214		
60	2.887	90	3.053	120	3.220		
61	2.892	91	3.059	121	3.225		
62	2.898	92	3.064	122	3.231		
63	2.903	93	3.070	123	3.237		
64	2.909	94	3.075	124	3.242		
65	2.914	95	3.081	125	3.248		
66	2.920	96	3.087	126	3.253		
67	2.925	97	3.092	127	3.259		
68	2.931	98	3.098	128	3.264		
69	2.937	99	3.103	129	3.270		

# CAPACITY CONTROLLERS – CAPL-2

## OVERVIEW

The Zonex Systems CAPL-2 is a combination staging and capacity control device for use with gas/electric units and heat pumps that use standard gas/electric thermostats. It can stage an economizer, two stages of cooling and up to two compressors and two stages of heat. The CAPL-2 monitors the leaving air temperature and stages the cooling or heating to maintain the leaving air temperature within a fixed range. Controlling the staging based on the leaving air temperature ensures the supply always matches the load. This is essential with a zoning system since the load varies substantially as the number of zones calling varies.

**Cool Mode** – When there is a cool call, if the leaving air is above the cool cut-in temperature, the CAPL-2 turns on the next stage compressor after a time delay. If the air gets too cold, it turns off the last stage compressor after that compressor has run a minimum of four minutes. As long as there is a cool call, when a compressor turns off it will stay off for a minimum of four minutes if the jumper is on ECON and when a compressor turns on it will run a minimum of four minutes. This prevents short cycling and ensures sufficient compressor oil return. When the cool call is removed, all compressors are immediately turned off.

**Heat Mode (Gas/Electric)** – If the leaving air is below the heat cut-in temperature, it turns on the next heat stage after a time delay. If the air gets too warm, it turns off the last heat stage after a time delay. When the heat call is removed, all heat stages turn off immediately.

**Heat Mode (Heat Pump)** – When there is a heat call, if the leaving air is below the heat cut in temperature, the CAPL-2 turns on the next stage heat after a time delay. If the air gets too warm, it turns off the last stage heat after that stage has run a minimum of four minutes. As long as there is a heat call, when a heat stage turns off, it will stay off for a minimum of four minutes and when a heat stage turns on it will run a minimum of four minutes. This prevents short cycling and ensures sufficient compressor oil return. When the heat call is removed, all compressors are immediately turned off.

## SEQUENCE OF OPERATION

The following sequence of operation assumes the cool cut-out setpoint is 48 degrees Fahrenheit and the heat setpoint is 150 degrees for gas/electric units and 118 degrees for heat pump units. For any other cut-out settings, add or subtract the difference to the values stated. Example: If your actual cool cut-out is 50 degrees, add 2 degrees to each temperature value stated under the Cooling Call section. All temperatures are in degrees Fahrenheit.

**COOLING CALL** (cool setpoint 48): As long as there is a cooling call (YIN energized), the following will occur.

### ECONOMIZER:

- As long as there is a cooling call the economizer, if available, is enabled and outside air is supplied based on enthalpy. The Economizer selection jumper must be on ECON if there is an economizer. If no economizer, place jumper on ECOFF.

### COMPRESSOR STAGING ON:

- If the **leaving air is 58 degrees or greater** and no compressors are running, compressor one will turn on within six minutes. If compressor one is running, compressor two will turn on within eight minutes.

### COMPRESSOR STAGING OFF:

- If the **leaving air is between 48 and 52 degrees** and compressor two is running, compressor two will shut off after running a minimum of four minutes. Compressor one will shut off after it has been on a minimum of four minutes and compressor two has been off a minimum of six minutes.
- If the **leaving air is 48 degrees or less**, then all compressors will turn off after the last compressor running has run for at least four minutes.

### NO STAGING:

- If the **leaving air is equal to or greater than 52 and less than 58 degrees**, then no compressor staging will occur.

**HEATING CALL (Gas/Electric)** (The factory heat setpoint is 150. Heat setpoint may be field modified to compensate for local temperatures

## WIRING – CAPL-2

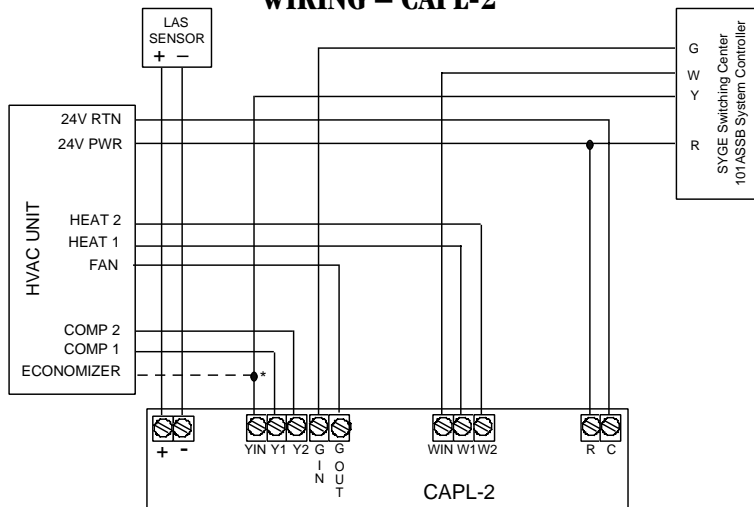

\*Lennox L Series Units may require a direct connection from YIN to the Economizer.

# CAPACITY CONTROLLERS – CAPL-2

and field conditions. For example, in milder climates setting may be as low as 110 to 115 degrees. In more severe climates up to 150 degrees.) As long as there is a heating call (WIN energized), the following will occur.

## HEAT STAGING ON:

- If the **leaving air is 130 degrees or less** and heat one is off, heat one will turn on within four minutes. If heat one is on, heat two will turn on within ten minutes.

## HEAT STAGING OFF:

- If the **leaving air is between 145 and 150 degrees** and heat two is running, heat two will turn off. Heat one will turn off after 150 Degree setpoint is exceeded
- If the **leaving air is 150 degrees or greater** then all heat stages will turn off and the indoor blower fan is energized until heat one turns back on or until the heat call is satisfied.

**NO STAGING:** If the **leaving air is greater than 130 and less than or equal to 145 degrees**, then no heat staging will occur.

**HEATING CALL (Heat Pump)** (heat setpoint 118). As long as there is a heating call (WIN energized), the following will occur:

## HEAT STAGING ON:

- If the **leaving air is 98 degrees or less** and heat one is off, heat one will turn on within four minutes. If heat one is on, heat two will turn on within eight minutes.

## HEAT STAGING OFF:

- If the **leaving air is between 113 and 118 degrees** and heat two is on, heat two will shut off after running a minimum of four minutes. Heat one will turn off after it has been on a minimum of four minutes and heat two has been off a minimum of six minutes.
- If the **leaving air is 118 degrees or greater** then all heat stages will turn off after the last heat stage running has run for at least four minutes.

## NO STAGING:

- If the **leaving air is greater than 98 and less than or equal to 113 degrees**, then no heat staging will occur.

## COMPONENTS

The CAPL-2 consists of the following:

**A. Digital Display** – Three digit LED. Normally displays the leaving air temperature of the HVAC unit. When the UP/DN buttons are pressed, the cut-out setpoints are displayed. Refer to the Setpoint Calibration section for reading and adjusting the setpoints.

**B. Microcontroller** – Activates and controls outputs based upon leaving air temperature comparison with programmed setpoint. Occasionally software upgrades may become available. If so, the CAPL-2 software can be field upgraded by changing this microcontroller.

**C. Thermometer Calibrator** – Calibrates the leaving air temperature thermometer. Turn clockwise to lower temperature. Turn counterclockwise to raise. Refer to CALIBRATION section for complete calibration information.

## D. Economizer Selection Jumper:

- ECON – Place here if you have an economizer.
- ECOFF – Place here if no economizer.

**E. Leaving Air Sensor (LAS) Terminals** – Leaving air temperature sensor is connected to the CAPL-2 here. Red to + and white to -. The sensor monitors the leaving air of the HVAC system. If preferred, the CAPL-2 can be mounted up to 500 feet from the sensor. See Installation section for further information.

**F. HVAC/System Controller Interface Terminals** – Y IN – Cool call input, Economizer output; Y1 – Compressor 1; Y2 – Compressor 2; G – Indoor blower fan; W IN – Heat call input; W1 – Heat 1; W2 – Heat 2. See Wiring section for detailed wiring instructions.

**G. HVAC Power Terminals** – Connect to HVAC system 24V AC power source. R is 24 V hot. C is 24 V rtn. Cannot be connected to any other power source. CAPL-2 uses less than 2 VA of power. See Wiring section for detailed wiring instructions.

**H. Status Lights – ECONO** – On during cool call. Indicates economizer enabled; Y1 – On when first stage compressor energized; Y2 – On when second stage compressor energized; Y3 – On when third stage compressor energized; Y4 – On when fourth stage compressor energized; FAN – On when indoor blower fan energized by System Controller or CAPL-2 (G energized); W1 – On when first stage furnace energized; W2 – On when second stage furnace energized; W3 – On when third stage furnace energized; W4 – On when fourth stage furnace energized.

**I. Power Switch** – When off, the display is off, the CAPL-2 is disabled and the relay contacts are closed. The HVAC unit can run at this time but will not have staging control or capacity control protection. When the switch is on, the display is on, and the CAPL-2 is operational.

**J. Board Number** – This number indicates the circuit board number and revision. May need to know this number if conferring with technical support.

**K. Heat Pump/Gas Electric selection jumper** – Place at GE position for gas/electric units. Place at HP position for heat pump units that use gas/electric thermostats.

**L. Setpoint Adjustment** – Use the UP/DN buttons to view and change the cutout setpoints. Refer to the Setpoints, Calibration section (Page 41) for reading and adjusting the setpoints.

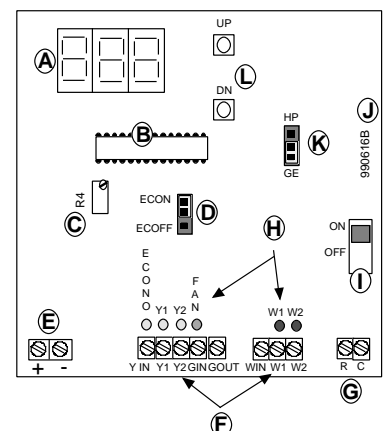

# CAPACITY CONTROLLERS – CAPL-4

## OVERVIEW

The Zonex Systems CAPL-4 is a combination staging and capacity control device in one. It can stage an economizer and up to four compressors and up to four stages of heat. The CAPL-4 monitors the leaving air temperature and stages the cooling or heating to maintain the leaving air temperature within a fixed range. Controlling the staging based on the leaving air temperature ensures the supply will always match the load. This is essential with a zoning system, since the load varies substantially as the number of zones calling varies.

**Cool mode** – When there is a cool call, if the leaving air is above the cool cut-in temperature, the CAPL-4 turns on the next stage compressor after a time delay. If the air gets too cold, it turns off the last stage compressor after that compressor has run a minimum of four minutes. As long as there is a cool call, when a compressor turns off it will stay off for a minimum of four minutes and when a compressor turns on it will run a minimum of four minutes. This prevents short cycling and ensures sufficient compressor oil return. When the cool call is removed, all compressors are immediately turned off.

**Heat mode** – If the leaving air is below the heat cut-in temperature, it turns on the next heat stage after a time delay. If the air gets too warm, it turns off the last heat stage after a time delay. When the heat call is removed, all heat stages turn off immediately.

## OPERATION

The following sequence of operation assumes the cool cut-out setpoint is 48 and the heat is 150 degrees Fahrenheit. For any other cut-out settings, add or subtract the difference to the values stated. Example: If your actual cool cut-out is 50 degrees, add 2 degrees to each temperature value stated under the Cooling Call section. All temperatures are in degrees Fahrenheit.

**COOLING CALL** (cool setpoint 48): As long as there is a cooling call (YIN energized), the following will occur.

### ECONOMIZER:

As long as there is a cooling call the economizer, if available, is enabled and outside air is supplied based on enthalpy.

### COMPRESSOR STAGING ON:

If the **leaving air is 58° or greater**, the next compressor will turn on within four minutes. As long as the air temperature remains within this range the next higher compressor will stage on every four minutes.

### COMPRESSOR STAGING OFF:

If the **leaving air is between 48 and 52°**, the highest compressor stage on will shut off within four minutes. As long as the air temperature remains within this range the next highest running compressor will stage off every four minutes.

If the **leaving air is 48° or less** then all compressors will turn off after the last compressor running has run for at least four minutes.

### NO STAGING:

If the **leaving air is equal to or greater than 52 and less than 58°** then no compressor staging will occur.

**HEATING CALL** (heat setpoint 150). As long as there is a heating call (WIN energized), the following will occur.

### HEAT STAGING ON:

If the **leaving air is 130° or less**, the next heat stage will turn on within four minutes. As long as the air temperature remains within this range the next higher heat stage will turn on every four minutes.

### HEAT STAGING OFF:

If the **leaving air is between 145 and 150°** the highest heat stage on will shut off within four minutes. As long as the air temperature remains within this range the next highest heat will stage off every four minutes.

If the **leaving air is 150° or greater** then all heat stages will turn off.

## COMPONENTS

The CAPL-4 consist of the following:

**A. Digital Display** – Three digit LED. Normally displays the leaving air temperature of the HVAC unit. When the UP/DN buttons are pressed, the cut-out setpoints are displayed. Refer to the Setpoint Calibration section for reading and adjusting the setpoints.

**B. Microcontroller** – Activates and controls outputs based upon leaving air temperature comparison with programmed setpoints. Occasionally software upgrades may become available. If so, the CAPL-4 software can be field upgraded by changing this microcontroller.

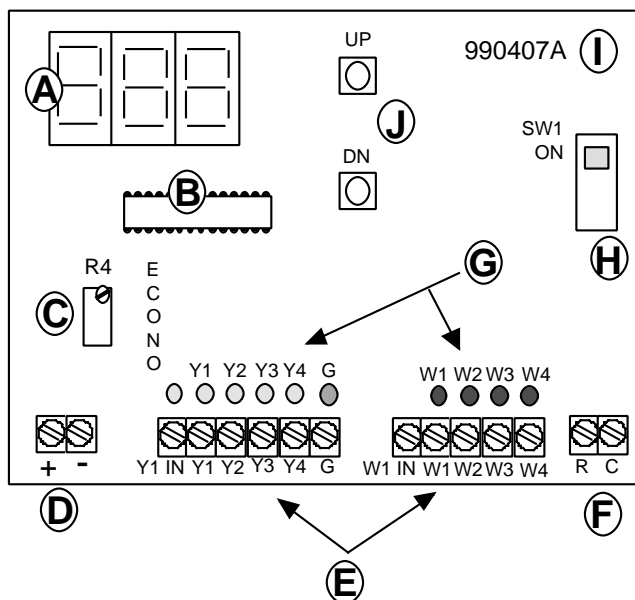



# CAPACITY CONTROLLERS - CAPL-4

**C. Thermometer Calibrator** – Calibrates the leaving air temperature thermometer. Turn clockwise to lower temperature. Turn counter-clockwise to raise. Refer to CALIBRATION section for complete calibration information.

**D. Leaving Air Sensor (LAS) Terminals** – Leaving air temperature sensor is connected to the CAPL-4 here. Red to + and white to -. The sensor monitors the leaving air of the HVAC system. If preferred, the CAPL-4 can be mounted up to 500 feet from the sensor. See INSTALLATION section for further information.

**E. HVAC/System Controller Interface Terminals** – Y IN – Cool call input, Economizer output; Y1 – Compressor 1; Y2 – Compressor 2; Y3 – Compressor 3; Y4 – Compressor 4; G – Indoor blower fan; W IN – Heat call input; W1 – Heat 1; W2 – Heat 2; W3 – Heat 3; W4 – Heat 4. See WIRING section for detailed wiring instructions.

**F. HVAC power terminals** – Connect to HVAC system 24V AC power source. R is 24 V hot. C is 24 V rtn. Cannot be connected to any other power source. CAPL-4 uses less than 2 VA of power. See WIRING section for detailed wiring instructions.

**G. Status Lights** – ECONO – On during cool call. Indicates economizer enabled; Y1 – On when first stage compressor energized; Y2 – On when second stage compressor energized; Y3 – On when third stage compressor energized; Y4 – On when fourth stage compressor energized; FAN – On when indoor blower fan energized by System Controller or CAPL-4 (G energized); W1 – On when first stage furnace energized; W2 – On when second stage furnace energized; W3 – On when third stage furnace energized; W4 – On when fourth stage furnace energized.

**H. Power Switch** – When off, the display is off, the CAPL-4 is disabled and the relay contacts are closed. The HVAC unit can run at this time but will not have staging control or capacity control protection. When the switch is on, the display is on and the CAPL-4 is operational.

**I. Board Number** – This number indicates the circuit board number and revision. May need to know this number if conferring with technical support.

**J. Setpoint Adjustment** – Use the UP/DN buttons to view and change the cut-out setpoints. Refer to the Setpoint, Calibration section (Page 41) for reading and adjusting the setpoints.

## WIRING – CAPL-4

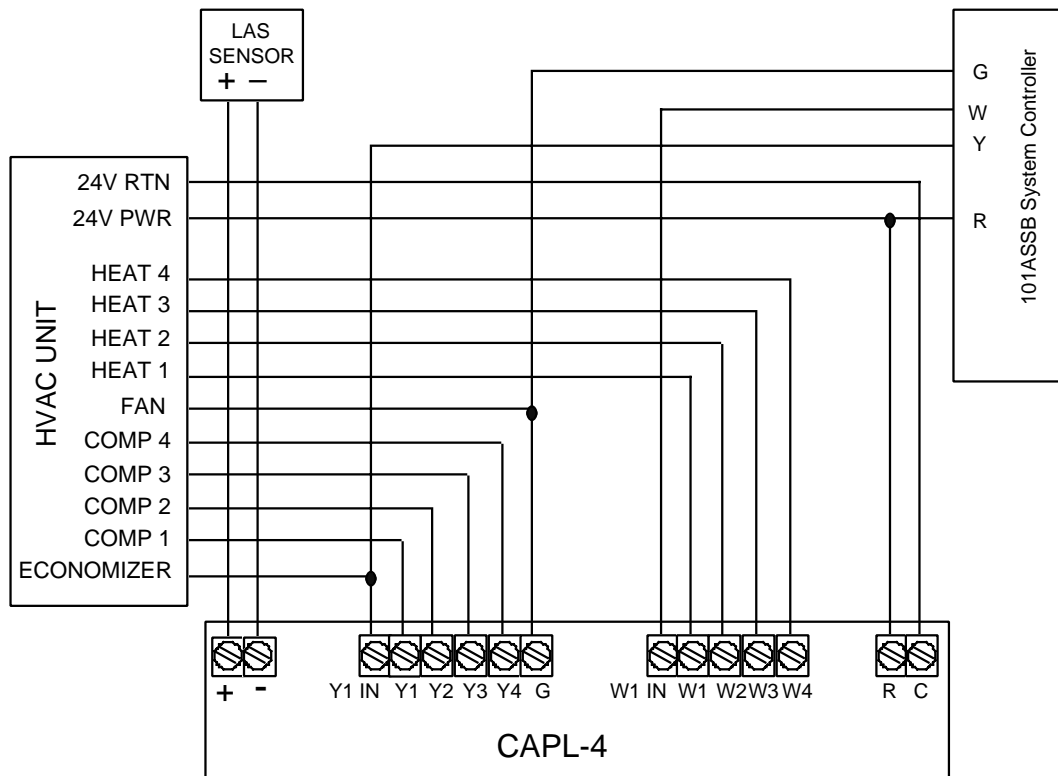

# CAPACITY CONTROLLERS – INSTALLATION

- A. Select location to place sensor. For gas/electric HVAC systems, sensor must be in leaving air duct, preferably as far from the coil/heat exchanger as possible but not past the bypass tap. For heat pumps, sensor must be placed between coil and auxiliary heat. If heat pump does not have auxiliary heat, place sensor as specified for gas/electric system. **See Figure 1.**
- B. Cut or drill a hole in selected location large enough to fit sensor through.
- C. For 101CAPGE, TRLAT, SYCAP, CAPL-2 and CAPL-4, determine if Capacity Controller will be mounted integral with sensor or remote from sensor. Mounting sensor remotely enables you to place the Capacity Controller in a location easily visible and serviceable.
- D. For the 101ALAS, TRFPC, or if mounting any other model with the sensor integral with Capacity Controller, place sensor through hole made in duct and mount Capacity Controller to duct with screws. Use grommet or tape to protect sensor wire from sharp edges. **See Figure 2.**
- E. If mounting sensor remotely, refer to **Figure 3** and do the following:
  1. On Capacity Controller, loosen + and – terminal screws and disconnect sensor.
  2. Remove circuit board screws and pull circuit board away from casing.
  3. Pull sensor out of casing.
  4. Reattach circuit board to casing with screws previously removed.
  5. Place sensor in hole made in duct and secure with tape, wire tie or cable clamp. Use grommet or tape to protect sensor wire from sharp edges.
  6. Select location for Capacity Controller and mount with screws.
  7. Wire sensor to Capacity Controller, red to + and white to –. If less than 200 feet, use separate 18 gauge, two conductor wire. If over 200 feet, use separate two conductor shielded wire and connect shield to TR2 or C terminal of Capacity Controller.

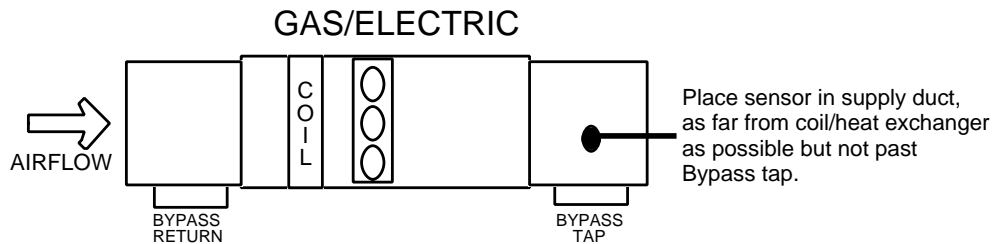

**Figure 1. Sensor Location**

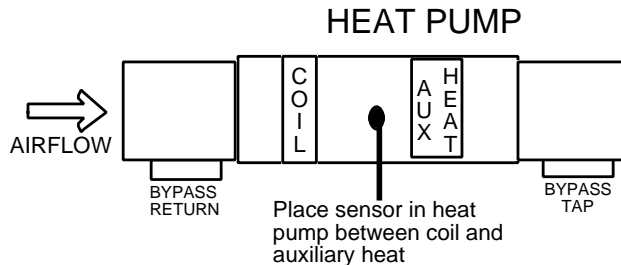

**Figure 2. Capacity Controller Mounted with Sensor**

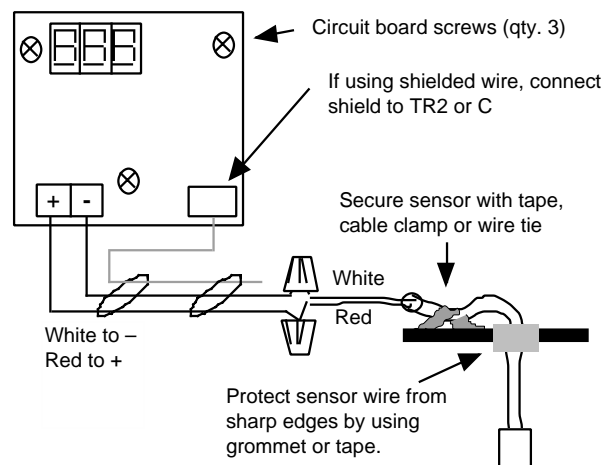

**Figure 3. Capacity Controller with Remote Sensor**

# CAPACITY CONTROLLERS – SETPOINTS, CALIBRATION

The following applies to the

**101CAPGE,  
CAPL-2,  
CAPL-4 and  
SYCAP Setpoints:**

There are two cut-out setpoints, one for heat and one for cool. The digital display normally displays the leaving air temperature of the HVAC/heat pump unit. By pressing the UP and DN buttons, the setpoints can be viewed and changed.

**Cool Setpoint** – To read the cool cut-out setpoint, press the DN button until “C” appears and then release. The number that follows is the cool cut-out setpoint. After a couple of seconds the leaving air temperature will be redisplayed. To change the setpoint, press the bottom or down button until the “C” is displayed, then immediately after the setpoint is displayed press and hold the UP/DN button till setpoint is at the desired value.

**Heat Setpoint** – To read the heat cut-out setpoint, press the UP button until “H” appears and then release. The number that follows is the heat cut-out setpoint. After a couple of seconds the leaving air temperature will be redisplayed. To change the setpoint, press the top or up button until the “H” is displayed, then immediately after the setpoint is displayed press and hold the UP/DN button till setpoint is at the desired value.

**Auxiliary Heat Setpoint** – For the SYCAP only, to read the auxiliary heat setpoint, press the UP and DN buttons simultaneously until “E” appears and then release. The number that follows is the auxiliary heat setpoint. After a couple of seconds the leaving air temperature will be redisplayed. To change the setpoint, immediately after the setpoint is displayed press and hold the UP/DN button till the setpoint is at the desired value.

## CALIBRATION

The digital display normally displays the leaving air temperature of the internal thermometer. This thermometer is factory calibrated. If calibration is ever required, turn the Thermometer Calibrator clockwise to lower the temperature. Turn counterclockwise to raise.

# FIVE WIRE LINK

Zonex Systems’s patented Five Wire Link is one of the most important elements of the System 1000/2000 zoning system. Extra care should be made to ensure the wiring is done correctly. The color code must be strictly followed. Ensure the stripped wire leads are not touching each other at the terminal blocks. If putting two wires into one terminal block, use the same gauge wire for both and ensure they are seated properly.

You must ensure the wire is sized properly to match the power needs of the number of dampers installed. The more dampers used, the greater the current draw and the greater the voltage loss on the Five Wire Link. If too much voltage is lost on the Five Wire Link, there will not be enough voltage at the zone dampers to properly operate them. To ensure the correct wire size, use the following table. Select the row matching the number of zone dampers you have. Move across horizontally to the column that matches the distance from the System Controller to the farthest damper. Use the wire size specified at the row/column intersection.

To reduce wire size, you can run more than one Five Wire Link Daisy Chain. Example: If you have 10 dampers, and the maximum distance is 200 feet, you would need 12 GA wire. If instead, you used two Five Wire Links with 5 dampers on each, you would now only need 18 GA wire for each daisy chain. Multiple daisy chains are wired color to color at the System Controller.

**NOTE: Never use less than 18 GA wire on the 5 Wire Link.**

NUMBER OF ZONE DAMPERS	WIRE LENGTH			
	50'	100'	150'	200'
1	18 GA	18 GA	18 GA	18 GA
2	18 GA	18 GA	18 GA	18 GA
3	18 GA	18 GA	18 GA	18 GA
4	18 GA	18 GA	18 GA	18 GA
5	18 GA	18 GA	18 GA	18 GA
6	18 GA	18 GA	18 GA	16 GA
7	18 GA	18 GA	18 GA	16 GA
8	18 GA	18 GA	16 GA	16 GA
9	18 GA	18 GA	16 GA	14 GA
10	18 GA	18 GA	16 GA	14 GA
11	18 GA	16 GA	16 GA	14 GA
12	18 GA	16 GA	14 GA	14 GA
13	18 GA	16 GA	14 GA	12 GA
14	18 GA	16 GA	14 GA	12 GA
15	18 GA	16 GA	14 GA	12 GA
16	18 GA	14 GA	14 GA	12 GA
17	18 GA	14 GA	12 GA	12 GA
18	18 GA	14 GA	12 GA	12 GA
19	18 GA	14 GA	12 GA	12 GA
20	18 GA	14 GA	12 GA	12 GA

# TRANSFORMER / FUSE SIZING

**Transformer/fuse sizing:** The 24V transformer connected to TR1 and TR2 of the Switching Center/System Controller powers the zone dampers, zone thermostats and Switching Center/System Controller. The power rating of the transformer must be sufficient to power the number of dampers used. Also, a properly rated in line fuse must be used on the secondary of the transformer. To determine the power rating of the transformer and the amperage rating of the fuse, use the table above.

**Note:** If using both spring open and power open dampers, size as if all dampers are spring open.

NUMBER OF DAMPERS	LOW PRESSURE (SPRING OPEN) DAMPERS		MED. PRESSURE/HEAVY DUTY (POWER OPEN) DAMPERS	
	XFMR PWR	FUSE SIZE	XFMR PWR	FUSE SIZE
1	12 VA	1 AMP	6 VA	1 AMP
2	24 VA	2 AMP	12 VA	1 AMP
3	36 VA	2 AMP	18 VA	1 AMP
4	48 VA	3 AMP	24 VA	2 AMP
5	60 VA	3 AMP	30 VA	2 AMP
6	72 VA	4 AMP	36 VA	2 AMP
7	84 VA	5 AMP	42 VA	3 AMP
8	96 VA	5 AMP	48 VA	3 AMP
9	108 VA	6 AMP	54 VA	3 AMP
10	120 VA	6 AMP	60 VA	3 AMP
11	132 VA	7 AMP	66 VA	4 AMP
12	144 VA	7 AMP	72 VA	4 AMP
13	156 VA	8 AMP	78 VA	4 AMP
14	168 VA	9 AMP	84 VA	5 AMP
15	180 VA	9 AMP	90 VA	5 AMP
16	192 VA	10 AMP	96 VA	5 AMP
17	204 VA	10 AMP	102 VA	5 AMP
18	216 VA	11 AMP	108 VA	6 AMP
19	228 VA	11 AMP	114 VA	6 AMP
20	240 VA	12 AMP	120 VA	6 AMP

# APPLICATION SCHEMATICS

## TYPICAL SETBACK/SETUP WIRING FOR ALL SWITCHING CENTERS AND SYSTEM CONTROLLERS

For continuous fan operation in the occupied mode and intermittent operation during unoccupied periods, leave the System Controller/Switching Center fan switch in the "ON" position.

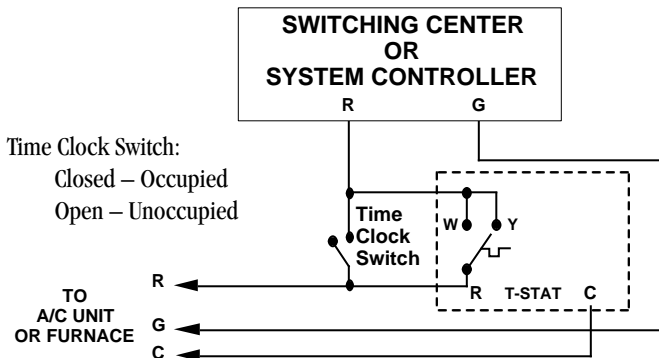

## WIRING THE ZONE DAMPER For Duct Supplemental Heat Applications

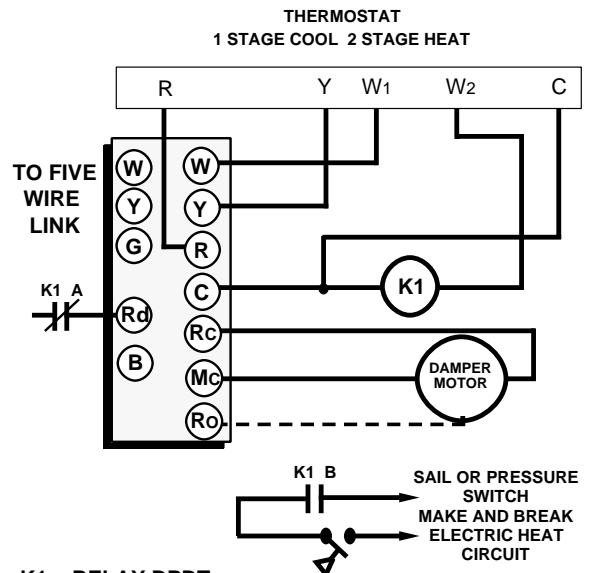

K1 = RELAY DPDT

**NOTE:** CONTACT "K1 A" IS ONLY REQUIRED FOR DUCT HEATER APPLICATIONS TO FORCE DAMPER TO THE OPEN POSITION

# APPLICATION SCHEMATICS

## CENTRAL & AUXILIARY BASE BOARD HEAT WIRING

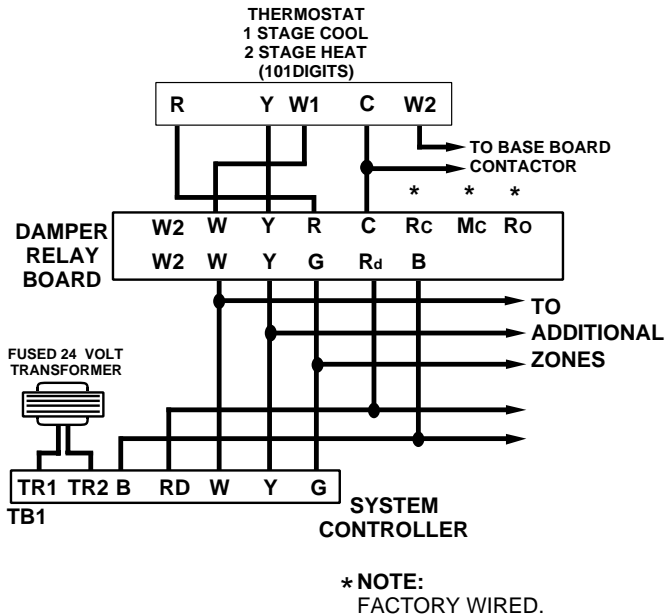

## BLOWER FAN RELAY

If the heater does not turn on the indoor blower fan when heat is on, you must add a blower fan relay as shown below. The relay will energize the fan signal "G" when the heat signal "W" is energized.

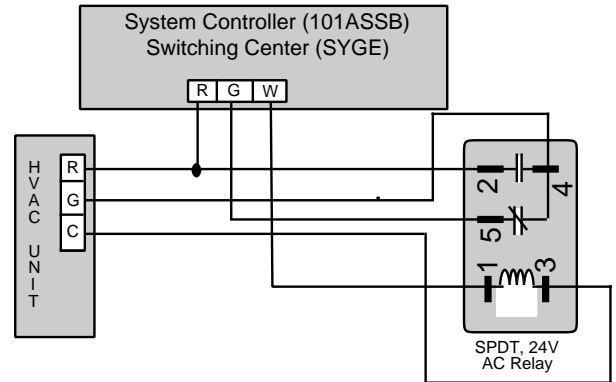

## ZONE FAN CONTROL

The Blower Fan Mode (AUTO/ON) is usually selected at the System Controller/Switching Center. If preferred, the Fan Mode can be selected at one zone thermostat using this diagram. The thermostat needs to have a fan switch.

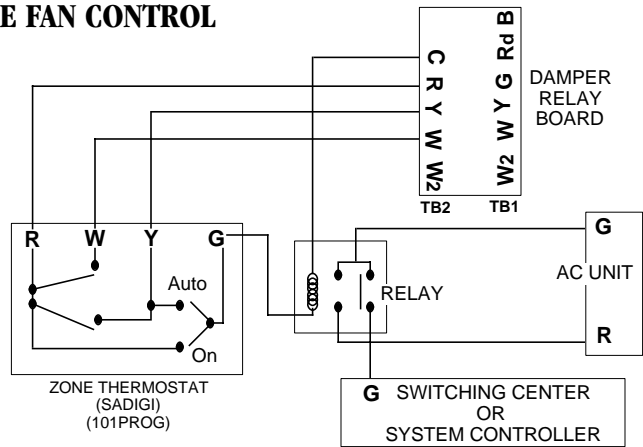

Note: Leave the fan switch in the "AUTO" position at the Switching Center or System Controller.

## ECONOMIZER INTERFACE FOR SWITCHING CENTERS AND SYSTEM CONTROLLERS NOT UTILIZING THE CAPL-2 OR CAPL-4.

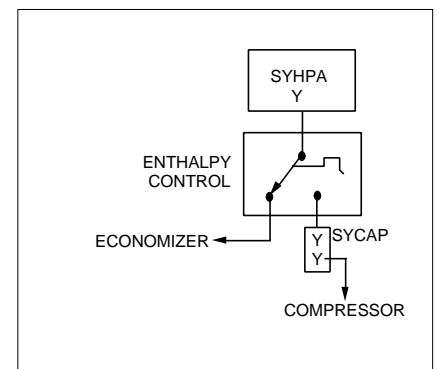
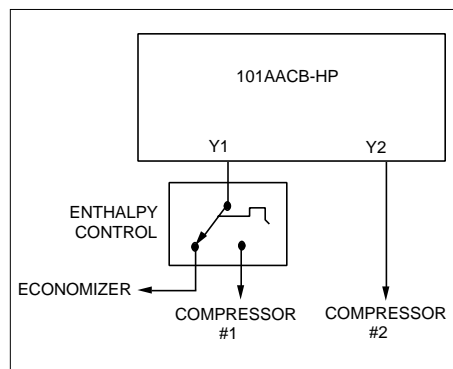
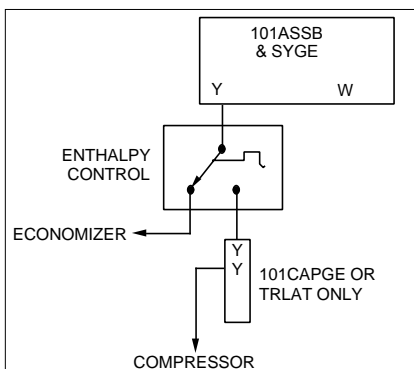

# SLAVING MULTIPLE DAMPERS

Each zone thermostat can control more than one damper. To determine when to use this application drawing, refer to Slaving Zone Dampers section on page 23.

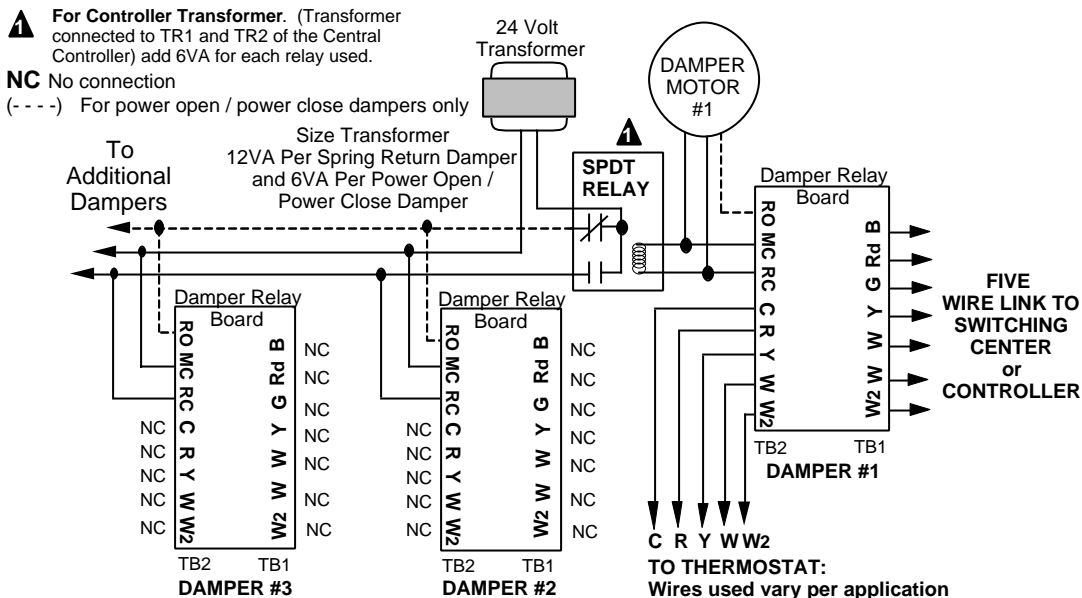

# PROPER BYPASS INSTALLATION WITH ECONOMIZER

When sizing a bypass damper, compute the system total air volume at 400 CFM/Ton and subtract the CFM of the smallest zone. The balance of the air can be bypassed at any one time. Refer to the Round and Rectangular damper CFM Charts. Choose the bypass closest to your CFM to bypass.

1. Outside Air Intake
2. Mixing Damper for Outside Air & Return Air
3. Pressure Relief of Outside Air from Building
4. Barometric Damper to Prevent Return Air Pressurization
5. Modulating Bypass Damper

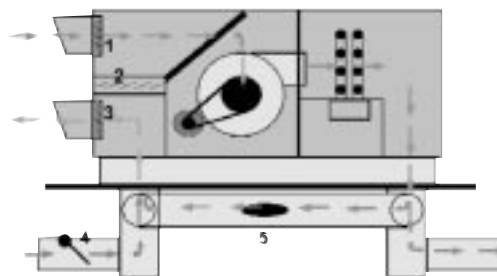

# WIRING A STAND ALONE DAMPER

When no system controller is used, use Zonex Systems's Digital, Auto Changeover Stand Alone Modulating Thermostat (SAMOD) in conjunction with an ST Series round or rectangular damper.

Listed below are some non-modulating solutions to stand alone applications if it is not possible to use a SAMOD.

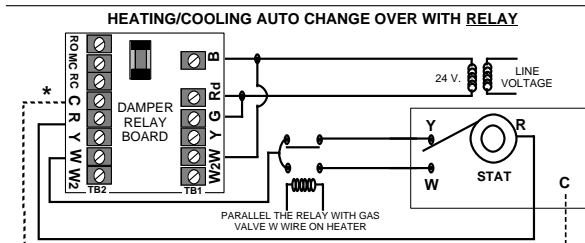
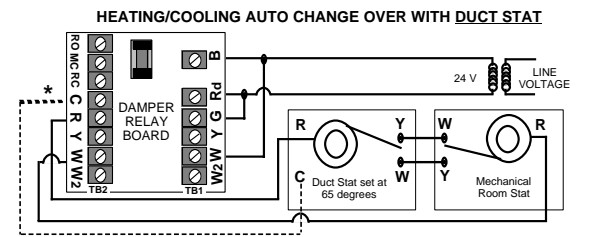
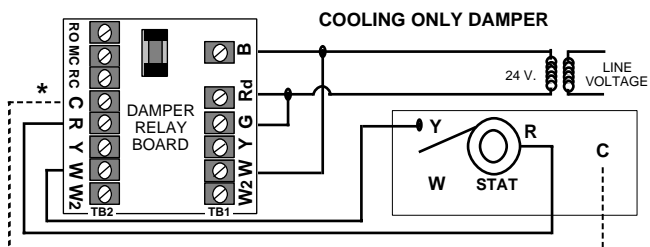

\* "C" Terminal used for electronic thermostats

## SYSTEM 1000/2000 TERMINAL DESCRIPTIONS

### Daisy Chain, 5 or 6 Wire Link:

1. GD/G Hot wire, 24V. Hot when Switching Center/Controller TR1 is hot. For System 2000, turning Controller Power switch off will remove power from GD. The Power switch will not remove power from GD on System 1000.
2. BD/B 24V return (chassis ground). Measure all Daisy Chain voltages in reference to this terminal.
3. RD Hot when the Switching Center/Controller recognizes a thermostat call. Damper light on Switching Center/ Controller is on when RD is hot.
4. YD/Y Cool call, hot when cool call recognized by Switching Center/Controller. For System 1000: 5V to 16V (1 to 7 zones calling). For System 2000: 212 mv to 3.64V (1 to 20 zones calling). There should never be 24V on this terminal when the System 1000 Switching Center green light is on and the mode switch is at "Cool" or when the System 2000 Controller's "Damper" and "Cool" lights are on. If there is, you have a short to either RD or GD.
5. WD/W Heat call, hot when heat call recognized by Switching Center/Controller. Voltages the same as for YD. There should never be 24V on this terminal when the System 1000 Switching Center green light is on and the mode switch is at "Heat" or when the System 2000 Controller's "Damper" and "heat" lights are on. If there is, you have a short to either RD or GD.
6. W2 Second stage heat call. 24V when second stage of zone thermostat is calling. Only used with System 1000 SYHPA.

### Damper Relay Board:

1. TB2:
  - a. MC Motor common. Return for 24V damper motor(s). Motor voltages measured in reference to this terminal.
  - b. RC Run Closed. 24V when damper motor closing.
  - c. RO Run Open. 24V when damper motor opening.
  - d. R 24V hot. Same as GD.
  - e. C 24V return. Same as BD.
  - f. W Thermostat heat call. See below how to determine if a zone is calling.
  - g. Y Thermostat cool call. See below how to determine if a zone is calling.
  - h. W2 Second stage thermostat heat call. Same as W2 on Daisy Chain.
2. TB1: Daisy Chain. See Daisy Chain, 5 or 6 Wire Link above.

## SYSTEM 1000/2000 TROUBLE SHOOTING

### To determine if a zone is calling:

On Damper Relay board, measure voltage from W to W and Y to Y (TB1 to TB2). If the voltage is at least 8 volts for System 1000 or 20 volts for System 2000, that zone is calling. If voltage is between W and W, zone is calling for heat. If between Y and Y, zone is calling for cool. To take this reading, RD must also be powered which means the Switching Center/Controller has recognized the call (Damper light on). Note: Do not test for a call by measuring the voltage from Y to C or W to C on TB2. The system utilizes pull up resistors which can give you false readings.

### If Controller/Switching Center transformer fuse is blowing:

1. Check for short on five wire link between RD and B or between G and B.
2. Check for short on thermostats between R and C.

### If Controller circuit board fuse is blowing (System 2000 only):

Make sure that the voltage between TR1 and TR2 is not less than 24 V or more than 30 V. If voltage is okay, replace Controller. If voltage is not within range, be sure you have the correct transformer and that the primary voltage is adequate. If primary voltage is okay and transformer is correct size, replace transformer.

### If Controller off circuit board fuse is blowing (System 2000 only):

You have a short on the five wire link between either Y and G, W and G, Y and Rd, or W and Rd.

### If System 1000 SYHPA Switching Center circuit board fuse is blowing:

You have a short on the five wire link between either YD and GD, WD and GD, YD and RD or WD and RD.

Zonex Systems  
**System 2000**

2-20 Zone Auto Changeover

**System 1000**

2-7 Zone Manual Changeover



**Hot Line: (800) 228-2966**

5622 Engineer Drive

Huntington Beach, CA 92649

Factory: (714) 898-9963 • Fax: (714) 898-6802

Visit our Web Site <http://www.hvaccomfort.com>

E-mail us at [calecon@hvaccomfort.com](mailto:calecon@hvaccomfort.com)

**Zoning**

**PATENTED PRODUCT**

Zonex Systems reserves the right to discontinue, or change at any time, specifications or designs without notice and without incurring obligations. Copyright 2003 by Zonex Systems, Inc.

Part #101ASIM  
Rev. September 2003